

NAYLOR METRODRAIN TWINWALL HIGHWAY DRAINAGE SYSTEM

NAYLOR METRODRAIN TWINWALL HIGHWAY DRAINAGE SYSTEM 150 MM TO 600 MM FITTINGS

This HAPAS Certificate Product Sheet⁽¹⁾ is issued by the British Board of Agrément (BBA), supported by Highways England (HE) (acting on behalf of the Overseeing Organisations of the Department for Transport; Transport Scotland; the Welsh Assembly Government and the Department for Infrastructure, Northern Ireland), the Association of Directors of Environment, Economy, Planning and Transport (ADEPT), the Local Government Technical Advisers Group and industry bodies. HAPAS Certificates are normally each subject to a review every three years.
(1) Hereinafter referred to as 'Certificate'.

This Certificate relates to Naylor Metrodrain Twinwall Highway Drainage System 150 mm to 600 mm Fittings, for use in conjunction with Naylor Metrodrain Twinwall Highway Drainage System 150 mm to 600 mm Pipes (the subject of Product Sheet 1 of this Certificate) in highway drainage.

CERTIFICATION INCLUDES:

- factors relating to compliance with HAPAS requirements
- factors relating to compliance with Regulations where applicable
- independently verified technical specification
- assessment criteria and technical investigations
- design considerations
- installation guidance
- regular surveillance of production
- formal three-yearly review.



KEY FACTORS ASSESSED

Strength — the products have adequate strength to resist loads associated with installation and service (see section 6).

Performance of joints — the products will remain watertight under normal service conditions (see section 7).

Durability — the products will have a service life in excess of 50 years (see section 10).



The BBA has awarded this Certificate to the company named above for the products described herein. These products have been assessed by the BBA as being fit for their intended use provided they are installed, used and maintained as set out in this Certificate.

On behalf of the British Board of Agrément



Paul Valentine
Technical Excellence Director



Claire Curtis-Thomas
Chief Executive

Date of Fifth issue: 2 July 2018

Originally certificated on 29 June 2009

The BBA is a UKAS accredited certification body – Number 113.

*The schedule of the current scope of accreditation for product certification is available in pdf format via the UKAS link on the BBA website at www.bbacerts.co.uk
Readers are advised to check the validity and latest issue number of this Agrément Certificate by either referring to the BBA website or contacting the BBA direct.
Any photographs are for illustrative purposes only, do not constitute advice and should not be relied upon*

Requirements

In the opinion of the BBA, Naylor Metrodrain Twinwall Highway Drainage System 150 mm to 600 mm Fittings, when used in accordance with the provisions of this Certificate, will meet or contribute to meeting the requirements of the *Manual of Contract Documents for Highways Works (MCHW)*⁽¹⁾, Volume 1 *Specification for Highways Works (SHW)*.

(1) The MCHW is operated by the Overseeing Organisations: Highways England (HE), Transport Scotland, the Welsh Assembly Government and the Department for Infrastructure (Northern Ireland).

Regulations

Construction (Design and Management) Regulations 2015

Construction (Design and Management) Regulations (Northern Ireland) 2016

Information in this Certificate may assist the client, designer (including Principal Designer) and contractor (including Principal Contractor) to address their obligations under these Regulations.

See sections: 3 *Delivery and site handling* (3.1) and 12 *General* of this Certificate.

Technical Specification

1 Description

1.1 Naylor Metrodrain Twinwall Highway Drainage System 150 mm to 600 mm Fittings comprise a range of fabricated polyethylene and polypropylene fittings with a black outer layer and a green inner layer, with the details and dimensions given in Figures 1 and 2.

Figure 1 Twinwall bends (all dimensions in mm)

11.25° bends

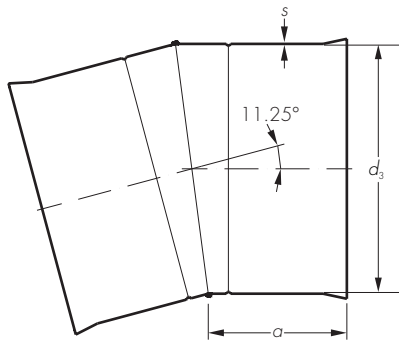

| For pipe size (nominal internal pipe diameter) | Minimum internal diameter d_3 | Nominal internal diameter at the coupler flare | Nominal dimensions | |
|--|--|---|-----------------------|-----|
| | | | a | s |
| 150 | 173.0 | 180.5 | 145 | 2.0 |
| 225 | 267.0 | 282.0 | 165 | 3.6 |
| 300 | 354.0 | 372.0 | 300 | 3.9 |
| 375 | 434.3 | 454.9 | 225 | 5.0 |
| 450 | 520.0 | 549.5 | 235 | 5.5 |
| 600 | 694.3 | 728.0 | 365 | 6.0 |

22.5° bends

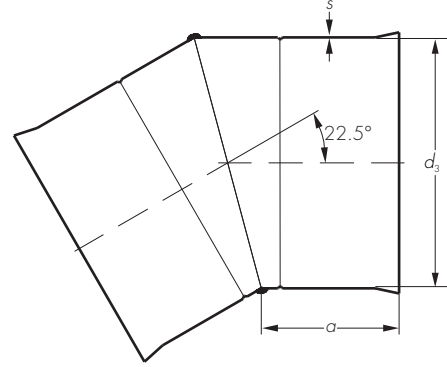

| For pipe size (nominal internal pipe diameter) | Minimum internal diameter d_3 | Nominal internal diameter at the coupler flare | Nominal dimensions | |
|--|--|---|-----------------------|-----|
| | | | a | s |
| 150 | 173.0 | 180.5 | 135 | 2.0 |
| 225 | 267.0 | 282.0 | 160 | 3.6 |
| 300 | 354.0 | 372.0 | 265 | 3.9 |
| 375 | 434.3 | 454.9 | 195 | 5.0 |
| 450 | 520.0 | 549.5 | 235 | 5.5 |
| 600 | 694.3 | 728.0 | 365 | 6.0 |

45° bends

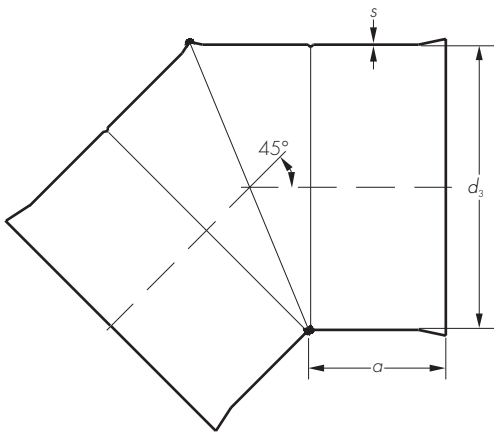

| For pipe size (nominal internal pipe diameter) | Minimum internal diameter d_3 | Nominal internal diameter at the coupler flare | Nominal dimensions | |
|--|--|---|-----------------------|-----|
| | | | a | s |
| 150 | 173.0 | 180.5 | 95 | 2.0 |
| 225 | 267.0 | 282.0 | 155 | 3.6 |
| 300 | 354.0 | 372.0 | 190 | 3.9 |
| 375 | 434.3 | 454.9 | 190 | 5.0 |
| 450 | 520.0 | 549.5 | 245 | 5.5 |
| 600 | 694.3 | 728.0 | 295 | 6.0 |

90° bends

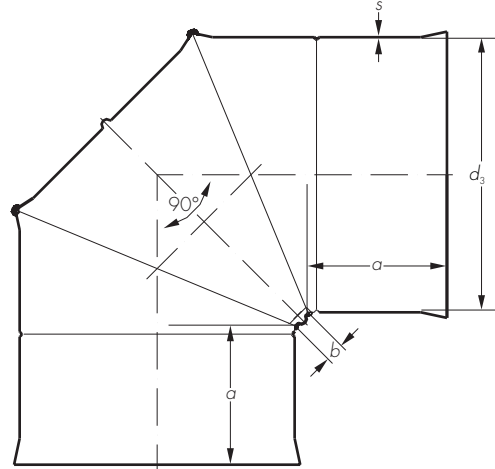

| For pipe size (nominal internal pipe diameter) | Minimum internal diameter d_3 | Nominal internal diameter at the coupler flare | Nominal dimensions | | |
|--|--|---|-----------------------|-----|-----|
| | | | a | b | s |
| 150 | 173.0 | 180.5 | 90 | 10 | 2.0 |
| 225 | 267.0 | 282.0 | 145 | 20 | 3.6 |
| 300 | 354.0 | 372.0 | 175 | 35 | 3.9 |
| 375 | 434.3 | 454.9 | 165 | 85 | 5.0 |
| 450 | 520.0 | 549.5 | 200 | 110 | 5.5 |
| 600 | 694.3 | 728.0 | 245 | 110 | 6.0 |

Figure 2 Twinwall junctions (all dimensions in mm)

45° junctions

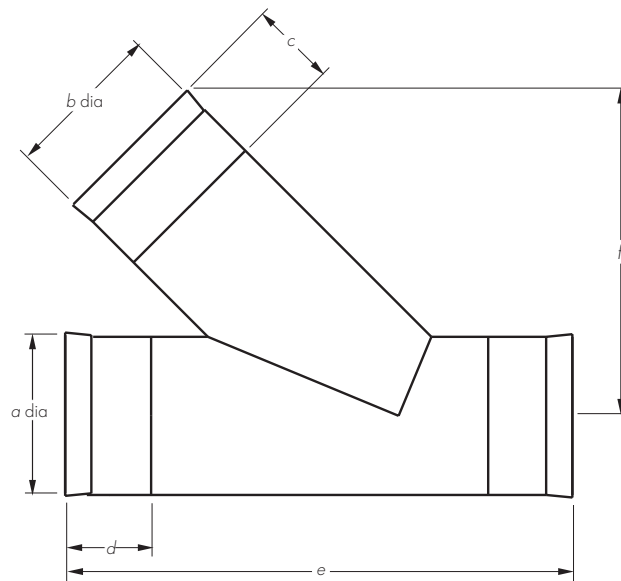

| For pipe size (nominal internal pipe diameter) | Minimum internal diameter a | For pipe size (nominal internal pipe diameter) | Minimum internal diameter b | Nominal dimensions | | | |
|--|-----------------------------------|--|-----------------------------------|--------------------|-----|------|------|
| | | | | c | d | e | f |
| 150 | 173.0 | 150 | 173.0 | 88 | 88 | 580 | 330 |
| 225 | 267.0 | 150 | 173.0 | 88 | 142 | 640 | 410 |
| 225 | 267.0 | 225 | 267.0 | 142 | 142 | 795 | 490 |
| 300 | 354.0 | 150 | 173.0 | 88 | 177 | 710 | 455 |
| 300 | 354.0 | 225 | 267.0 | 135 | 177 | 915 | 710 |
| 300 | 354.0 | 300 | 354.0 | 177 | 177 | 1010 | 640 |
| 375 | 434.3 | 150 | 173.0 | 88 | 165 | 910 | 490 |
| 375 | 434.3 | 225 | 267.0 | 142 | 165 | 1060 | 600 |
| 375 | 434.3 | 300 | 354.0 | 177 | 165 | 1285 | 700 |
| 375 | 434.3 | 375 | 434.3 | 165 | 165 | 1270 | 820 |
| 450 | 520.0 | 150 | 173.0 | 88 | 198 | 770 | 550 |
| 450 | 520.0 | 225 | 267.0 | 142 | 198 | 1140 | 780 |
| 450 | 520.0 | 300 | 354.0 | 177 | 198 | 1305 | 865 |
| 450 | 520.0 | 375 | 434.3 | 165 | 198 | 1515 | 1045 |
| 450 | 520.0 | 450 | 520.0 | 198 | 198 | 1515 | 965 |
| 600 | 694.3 | 150 | 173.0 | 88 | 242 | 950 | 625 |
| 600 | 694.3 | 225 | 267.0 | 142 | 242 | 1340 | 855 |
| 600 | 694.3 | 300 | 354.0 | 177 | 242 | 1340 | 940 |
| 600 | 694.3 | 375 | 434.3 | 165 | 242 | 1930 | 1120 |
| 600 | 694.3 | 450 | 520.0 | 198 | 242 | 1930 | 1260 |
| 600 | 694.3 | 600 | 694.3 | 242 | 242 | 1930 | 1140 |

Figure 2 Twinwall junctions (all dimensions in mm) (continued)

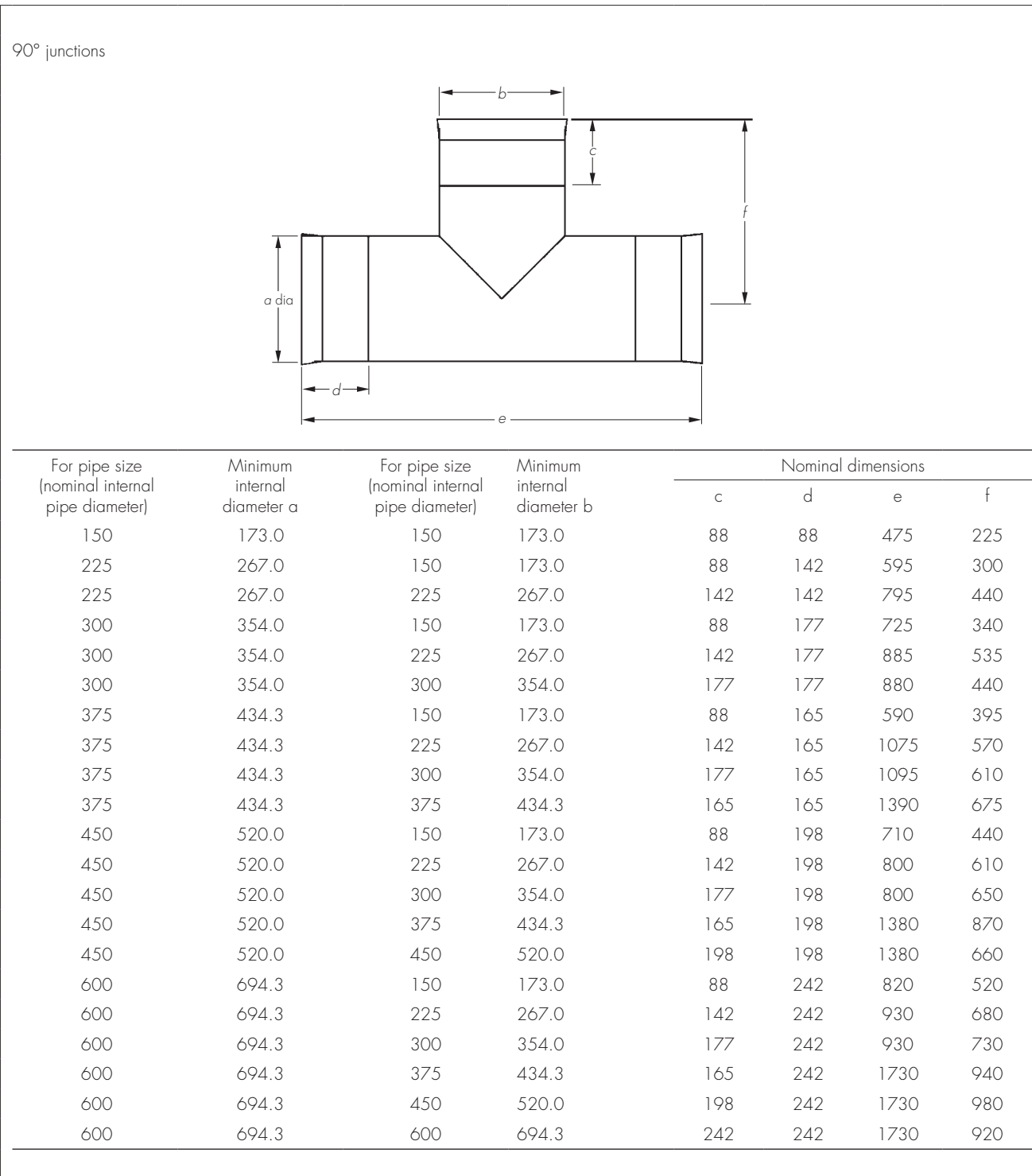

1.2 Each bend requires two rubber seals, and each junction requires three rubber seals manufactured to BS EN 681-1 : 1996, available from the Certificate holder. The seals must be fitted in accordance with the installation instructions to ensure a watertight joint.

2 Manufacture

2.1 The fittings are fabricated from pipes and couplers as described in Product Sheet 1 of this Certificate, welded together. The pipe sections are surrounded by a polypropylene sleeve and welded to the couplers.

2.2 As part of the assessment and ongoing surveillance of product quality, the BBA has:

- agreed with the manufacturer the quality control procedures and product testing to be undertaken
- assessed and agreed the quality control operated over batches of incoming materials
- monitored the production process and verified that it is in accordance with the documented process
- evaluated the process for management of nonconformities
- checked that equipment has been properly tested and calibrated

- undertaken to carry out the above measures on a regular basis through a surveillance process, to verify that the specifications and quality control operated by the manufacturer are being maintained.

2.3 The management system of Naylor Drainage Ltd has been assessed and registered as meeting the requirements of BS EN ISO 9001 : 2015 by BSI (Certificate FM 01420).

3 Delivery and site handling

3.1 Fittings are generally delivered prepacked in bags or on pallets and should be retained in their packaging until installation.

3.2 Handling, storage and transportation of the fittings must be in accordance with the Certificate holder's instructions, with care taken to avoid damage by dropping or dragging. They should be adequately supported at all times, and contact with sharp projections, protuberances and abrasive surfaces should be avoided.

3.3 When long-term storage is envisaged, the fittings must be protected from direct sunlight. If protection cannot be provided, consideration must be given to the effects of daily exposure to direct sunlight:

- up to 3 months — negligible UV degradation but possible extreme surface temperatures of up to 80°C may cause some localised distortion
- 3 to 12 months — may have significant effect on the impact resistance and physical properties of the products
- over 12 months — damage will occur unless protection is provided.

3.4 The Certificate holder can manufacture the fittings with enhanced UV stability if required.

Assessment and Technical Investigations

The following is a summary of the assessment and technical investigations carried out on Naylor Metrodrain Twinwall Highway Drainage System 150 mm to 600 mm Fittings.

Design Considerations

4 Use

Naylor Metrodrain Twinwall Highway Drainage System 150 mm to 600 mm Fittings comply with the requirements of the MCHW, Volume 1, Clauses 518.6 and 518.7. When installed with Metrodrain pipes (subject of Product Sheet 1 of this Certificate) in accordance with the recommendations given in this Certificate, they are satisfactory for use in highways for the collection and disposal of surface and sub-surface water.

5 Practicability of installation

The products must be installed by competent contractors experienced with these types of products using traditional drain-laying methods in accordance with HE requirements and the MCHW, Volume 1, Clauses 503, 505, 518.8 and 518.9. The lightness of the fittings in weight is a significant advantage during handling and installation.

6 Strength

6.1 The products have adequate strength to resist loads associated with installation and with subsequent use in the situations described in this Certificate.

6.2 The pipes from which the fittings are fabricated have a ring stiffness equal to or in excess of 6 kN·m⁻², a creep ratio of less than 4 and adequate resistance to static loads.

6.3 The fittings have adequate resistance to impact loads to which they may be subjected during installation and in service.

7 Performance of joints

When correctly made, joints constructed from connectors with rubber seals remain watertight when subjected to deflection and distortion, and comply with the MCHW, Volume 1, Clauses 504.3 and 518.7 (see section 14).

8 Flow characteristics

When used with the pipes described in Product Sheet 1, the products will increase the hydraulic resistance of the system. Loss coefficients (K values) may be taken as:

| | |
|--------------------|-------|
| 11.25° bends | 0.20 |
| 22.5° bends | 0.35 |
| 45° bends | 0.45 |
| 90° bends | 0.70 |
| branch connections | 1.00. |

9 Maintenance

9.1 Access to the products for cleaning should be provided by conventional methods.

9.2 Drains incorporating the products can be rodded readily using flexible drain rods. In common with other standard plastic drainage systems, toothed root cutters and rods with metal ferrules, as used with some mechanical clearing systems, could damage the fittings and should not be used.

9.3 Drains incorporating the products have adequate resistance to water cleansing using pressure-jetting equipment. It is recommended that low-pressure, high-volume systems are used in accordance with the MCHW, Volume 1, Clause 521.

10 Durability

In the opinion of the BBA, when the products are used in the context of this Certificate, the material from which the pipes and couplers are manufactured will not significantly deteriorate and the anticipated service life of the products will be in excess of 50 years.

11 Reuse and recyclability

The products are manufactured from polyethylene or polypropylene, which are recyclable.

Installation

12 General

Drains utilising Naylor Metrodrain Twinwall Highway Drainage System 150 mm to 600 mm Fittings must be installed in accordance with HE requirements and the MCHW, Volume 1, Clauses 503, 505, 518.8 and 518.9.

13 Procedure

13.1 Typical laying, trench and backfilling specification details are given in section 14 of Product Sheet 1 of this Certificate.

13.2 To make a joint, the pipe end and fitting socket should be cleaned and a rubber seal fitted externally between the first and second corrugation in the pipe. The seal and inside of the socket should be lubricated with a Naylor-approved lubricant and the pipe pushed fully home to the register, either by hand or using a lever if necessary.

13.3 Pipes and fittings must be protected from site construction traffic.

Technical Investigations

14 Tests

Tests were carried out and the results assessed to determine:

- dimensional accuracy
- rodding resistance to the MCHW, Volume 1, Clause 518.12
- determination of ring stiffness of the pipes the fittings are fabricated from to BS EN ISO 9969 : 2016
- impact resistance (drop test) to BS EN 12061 : 1999
- strength of flexibility of fabricated fittings to BS EN 12256 : 1998
- watertightness of fabricated fittings to BS EN 1053 : 1996
- joint test to BS EN 1277 : 2003 when subjected to diameter distortion and angular deflection
- water jetting WRc method.

15 Investigations

15.1 An assessment was made of data in relation to the effect of the production tolerances on the performance of the products.

15.2 An evaluation of existing data was made to assess material properties, chemical resistance and durability.

15.3 The manufacturing process was evaluated, including the methods adopted for quality control, and details were obtained of the quality and composition of the materials used.

Bibliography

BS EN 681-1 : 1996 *Elastomeric seals — Material requirements for pipe joint seals used in water and drainage applications — Vulcanized rubber*

BS EN 1053 : 1996 *Plastics piping systems — Thermoplastics piping systems for non-pressure applications — Test method for watertightness*

BS EN 1277 : 2003 *Plastics piping systems — Thermoplastics piping systems for buried non-pressure applications — Test methods for leaktightness of elastomeric sealing ring type joints*

BS EN 12061 : 1999 *Plastics piping systems — Thermoplastics fittings — Test method for impact resistance*

BS EN 12256 : 1998 *Plastics piping systems — Thermoplastics fittings — Test method for mechanical strength or flexibility of fabricated fittings*

BS EN ISO 9001 : 2015 *Quality management systems — Requirements*

BS EN ISO 9969 : 2016 *Thermoplastic pipes — Determination of ring stiffness*

Manual of Contract Documents for Highway Works, Volume 1 *Specification for Highway Works*

Conditions of Certification

17 Conditions

17.1 This Certificate:

- relates only to the product/system that is named and described on the front page
- is issued only to the company, firm, organisation or person named on the front page — no other company, firm, organisation or person may hold or claim that this Certificate has been issued to them
- is valid only within the UK
- has to be read, considered and used as a whole document — it may be misleading and will be incomplete to be selective
- is copyright of the BBA
- is subject to English Law.

17.2 Publications, documents, specifications, legislation, regulations, standards and the like referenced in this Certificate are those that were current and/or deemed relevant by the BBA at the date of issue or reissue of this Certificate.

17.3 This Certificate will remain valid for an unlimited period provided that the product/system and its manufacture and/or fabrication, including all related and relevant parts and processes thereof:

- are maintained at or above the levels which have been assessed and found to be satisfactory by the BBA
- continue to be checked as and when deemed appropriate by the BBA under arrangements that it will determine
- are reviewed by the BBA as and when it considers appropriate.

17.4 The BBA has used due skill, care and diligence in preparing this Certificate, but no warranty is provided.

17.5 In issuing this Certificate, the BBA is not responsible and is excluded from any liability to any company, firm, organisation or person, for any matters arising directly or indirectly from:

- the presence or absence of any patent, intellectual property or similar rights subsisting in the product/system or any other product/system
- the right of the Certificate holder to manufacture, supply, install, maintain or market the product/system
- actual installations of the product/system, including their nature, design, methods, performance, workmanship and maintenance
- any works and constructions in which the product/system is installed, including their nature, design, methods, performance, workmanship and maintenance
- any loss or damage, including personal injury, howsoever caused by the product/system, including its manufacture, supply, installation, use, maintenance and removal
- any claims by the manufacturer relating to CE marking.

17.6 Any information relating to the manufacture, supply, installation, use, maintenance and removal of this product/system which is contained or referred to in this Certificate is the minimum required to be met when the product/system is manufactured, supplied, installed, used, maintained and removed. It does not purport in any way to restate the requirements of the Health and Safety at Work etc. Act 1974, or of any other statutory, common law or other duty which may exist at the date of issue or reissue of this Certificate; nor is conformity with such information to be taken as satisfying the requirements of the 1974 Act or of any statutory, common law or other duty of care.