

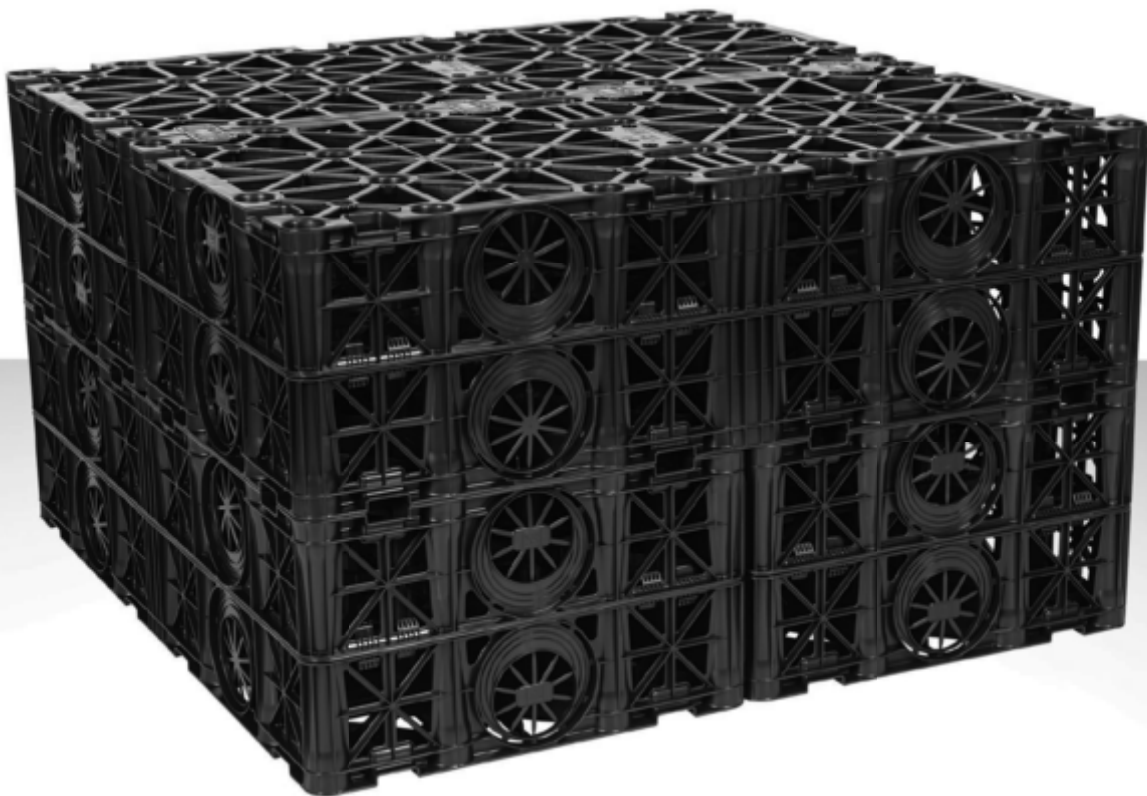

Plumbing & Drainage

StormCrate55

Stormwater Retention, Attenuation & Infiltration Crate



Design and Installation Guidance



Plumbing & Drainage



Stormwater Management Systems

Geocellular stormwater retention, attenuation and infiltration systems.

Product guide, design and installation guidance.

Drainage specialist Brett Martin has designed, developed, manufactured and tested StormCrate Modular Cellular crates for use in storm water retention, attenuation and infiltration applications.

All products are manufactured to exacting standards through the company's achievement of BS EN ISO 9001:2015. You can be confident that as a BSI registered firm our Quality Assurance Programme guarantees that each Brett Martin system is a first class product, ensuring the highest possible levels of performance.

Brett Martin also offers a comprehensive range of underground drainage systems. It includes the Drain, Sewer, Perforated, Surface Water and Cable Duct systems. The entire range incorporates pipes and fittings in fourteen diameters ranging from 53.9mm to 600mm.

This document provides design and installation guidance for StormCrates. Further guidance is available from Brett Martins technical team including:

- Installation guidance and advice
- Guidance on the suitability of our product for a particular site
- Technical support

For further information please call 01246 280000 or email building@brettmartin.com

Contents

SUDS Overview and Best Practice Guidelines	3
Planning	4
Types of Installation – Site Classification	5
Products	7
Testing	11
Design protocol	12
Hydraulic Design	22
Location Options	28
Installation	29
Chemical Resistance Chart	34

SUDS Overview and Best Practice Guidelines

SuDS, Sustainable Drainage Systems, are ways of managing the rainwater that falls on a site, so that it is beneficial to the environment and not harmful. It is most important in reducing the risk of flooding and reducing water-shortages, especially as these are becoming more frequent. The impact of SUDS on biodiversity, ecosystems and amenity, both on and near the site, can create a more vibrant, more resilient, more attractive place to live. It can also be cheaper and more carbon efficient than installing alternative or traditional drainage systems.

SUDS Design Solutions

- Slowing water using grassland, planting, or geoconstructions
- Holding water in ponds, rivers, channels, swales, or underground containers
- Cleaning water using vegetation, chemicals or mechanical methods
- Draining water away through infiltration into the ground, through channels into rivers or watercourses, or through pipes into the sewerage system.

SUDS design solutions can take many forms, from the most visible wildlife and amenity lakes, to the most discreet underground storage tanks. A complete SUDS solution usually incorporates a number of different water management systems to successfully address the specific aims, flow volumes, and conditions of the site.

Infiltration

Allowing rainwater to infiltrate back into the ground, keeps groundwater levels charged to a more natural level, which is beneficial for the surrounding natural environment. This is the first choice for rainwater management by Building Regulations Part H. Infiltration involves holding the water to stop it running off site, and keeping it while it soaks slowly into the ground. Because the water is going straight into the ground, the Environment Agency requires it to be clean, and not contaminate the ground or any downstream habitats. Brett Martin StormCrates with infiltration membranes and inflow traps are ideal for this purpose.

Attenuation

To manage the outflow of rainwater to a watercourse or a sewer (the second and third choices of Building Regulations Part H), the water first needs to be held, so that the outflow can be properly adjusted and maintained. Setting the outflow is vital so that the sewers and watercourses can safely handle the volume of runoff water at all times. Brett Martin StormCrates, with impermeable membranes and flow controls are ideal for this purpose.

SUDS Legislation

Building Regulations 2010 – H3 requires, in order of preference, that the rainwater from the roofs and paved areas of a site

1. Soak into the ground via infiltration ponds or tanks. Cleaned first, if necessary.
2. Be held by an attenuation tank which feeds into a river. Cleaned first, if necessary. The Environment Agency will recommend the maximum flow rates for this.
3. Be held by an attenuation tank which feeds into a sewer. Building Control will recommend the maximum flow rates for this.

CIRIA's best practise guidelines for SUDS installation (C753), call for rainwater runoff from a developed site to mimic natural site runoff characteristics, and not overload the conventional sewerage system. Attenuation and Infiltration systems slow and store rainwater so that this can be achieved.

Planning

Concept

All current legislation and best practice, calls for drainage designs to be incorporated into site development plans from the start. At the strategic, inception and concept stages, understanding the site characteristics, flood risks, water volumes, discharge options, and adoption requirements, allows these to inform the development as it progresses. This enables the most favourable opportunities to be considered, which can help inject character and amenity into a development, and can save expensive last minute reworking. For all sites, a site survey (desk based and on site) would provide this information. For larger sites, an Environmental Impact Assessment will greatly help to inform the SUDS design.

Outline

At this stage, sizes and volumes of SUDS features can be determined at site scale and sub-catchment scale. Links to the surrounding water network can be checked for feasibility. Amenity and siting of the SUDS within the development can be optimised. At this stage, Brett Martin is able to help calculate volumes for attenuation and infiltration, and can help design StormCrate configurations to achieve a required footprint, based on the site information gained during the concept stage.

Retrofitting

Once a development is complete, SUDS can be installed at a later date, to help alleviate flooding, mitigate the risk of flooding, provide rainwater harvesting or increase the wildlife or amenity value to the site. Brett Martin StormCrates are ideal for retrofitting.

Planning Legislation

The European Framework Directive protects groundwater against pollution and improves the ecological quality of community water resources for all catchment areas within Europe. The European Floods Directive calls for local flood risk assessments to be drawn up at a local level.

The UK's Floods and Water Management Act calls for the UK Environment Agency to highlight all local risks and local mitigation strategies to potential developers.

National Planning Policy Framework (superseding PPS25), favours development that is sustainable, and supports measures to ensure the resilience of communities and infrastructure in the face of climate change. All plans should manage flood risk and ensure that the risk is not increased downstream.

Local Strategic Plans and Neighbourhood Plans indicate proposed or existing measures to mitigate local flood risk. Integrating new development with these measures can have significant advantages.

BRE Digest 365, CIRIA C753 (formerly C697) and CIRIA 768, have more detailed information and guidance on the design of individual components of a SUDS system. Brett Martin StormCrates design and installation is based on this best practice.

Types of Installation – Site Classification

StormCrates are an underground earthworks structure, and as such, a certain amount of expertise is required in their configuration design and installation on site. CIRIA C737 gives guidance on the level of expertise required for different complexities of installation.

Very simple designs and installations, such as single dwelling, shallow installations on empty level ground with landscaping over, require no formal design checks, and minimal advice. Large installations on complex commercial sites may require the expertise of a senior specialist geotechnical engineer to oversee the design process. Most sites have a complexity between these two extremes, and will require the expertise of a competent building professional, with a chartered engineer to oversee checks.

Scoring System –

CIRIA C737 details a checklist which can be used to assign a score to an installation, this checklist can be found in CIRIA C737. The total score for a site can then be used to assign a classification between 0 and 3. This classification can then be used to plan design checks, methods of analysis and designer competence levels.

CLASSIFICATION	SCORE RANGE
0	0-25
1	26-80
2	81-120
3	≥121

Classification 0

For this classification there may be no formal design checks and the unit supplier will advise on the suitability of the product.

Design checks:

- Basic assessment of soil type to assess suitability for infiltration.
- Services search.

Classification 1

Simple design checks should be undertaken by a competent building professional and an incorporated or chartered engineer should oversee the work.

Design checks:

- Undertake checks for vertical distributed and concentrated loading.
- Check adequacy of cover to units for concentrated loading and ground water (flotation check).
- Assess “Active” pressures (Ka) for lateral load on installation.
- Standardised manufacturer information and testing, based on design life is likely to be sufficient.

Classification 2

As these installations are more complicated a Chartered civil engineer with 5 years post chartered specialised experience is recommended, a CAT II check may also be needed.

Design checks:

- As for class 1, ensuring all pre-construction information obtained, additionally further ground investigation should be considered.
- Sloping ground will require a more detailed assessment of lateral loading such as slope stability calculations and an assessment of pre-existing shear zones in slopes.
- Detailed assessment of the installation regarding construction activities, such as stockpiles, plant or crane operations.
- Detailed assessment of adjacent structures, retaining walls such as passive zones and load paths of foundations.

Classification 3

As the most complex classification a senior specialist geotechnical engineer of geotechnical advisor status should be appointed to oversee design process. It is likely that complex modelling and testing required.

For some installations, bespoke testing/analysis will be required and supervised by senior specialist geotechnical engineer.

Design checks:

- Bespoke testing/analysis required supervised by senior specialist geotechnical engineer or geotechnical advisor status.

Classification Examples

Examples of installations which typically fall into a specific class are shown below, it is important to note however that the site classification proforma found in CIRIA C737 should be followed for all installations in order to ensure that each site is classified correctly.

CLASSIFICATION	EXAMPLES
0	<ul style="list-style-type: none">• Domestic applications such as attenuation for a single house.
1	<ul style="list-style-type: none">• Located in agricultural land or remote landscaping.• Located beneath private access roads with occasional use less than 15mph.• Located beneath/adjacent to carparks with no HGV traffic (i.e. height and/or width barriers in place).
2	<ul style="list-style-type: none">• As for class 1, but soil structure interaction is potentially more complex.• Located beneath public roads, subject to low to moderate speed (less than 30mph) traffic.• Parking areas accessible to HGVs.
3	<ul style="list-style-type: none">• Located beneath/adjacent to public roads subject to high speed (more than 30mph) traffic.

Products

Product overview

KEY FEATURES AND BENEFITS

- Crate Dimensions 1200mm x 600mm x 347mm
- 95% void ratio providing a greater storage capacity than traditional solutions so that less excavation is required for the installation of a system
- Suitable for both attenuation and infiltration systems (surface water only)
- Manufactured using recycled materials reducing the impact of the system on the environment.
- Modular design allowing multiple units to be stacked in a variety of different shapes and layouts. This also means that shallower installations are possible
- Installation of a StormCrate system reduces the risk of flooding to provide a sustainable and cost effective water management system
- Factory assembled crates meaning that costly and time consuming assemble on site is not required
- 20 year design life

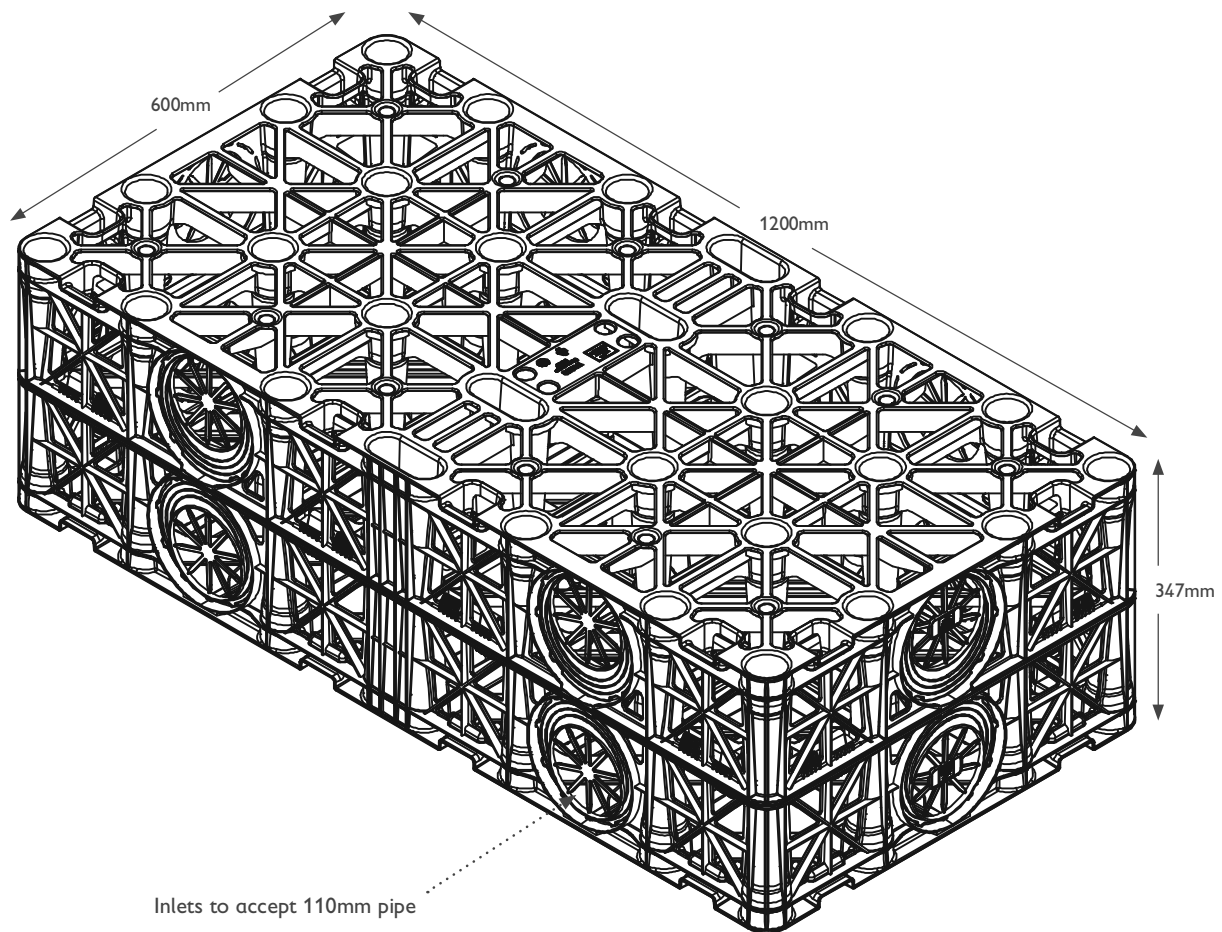

StormCrate – can be assembled
in multiple configurations

Shear Pin

Connector

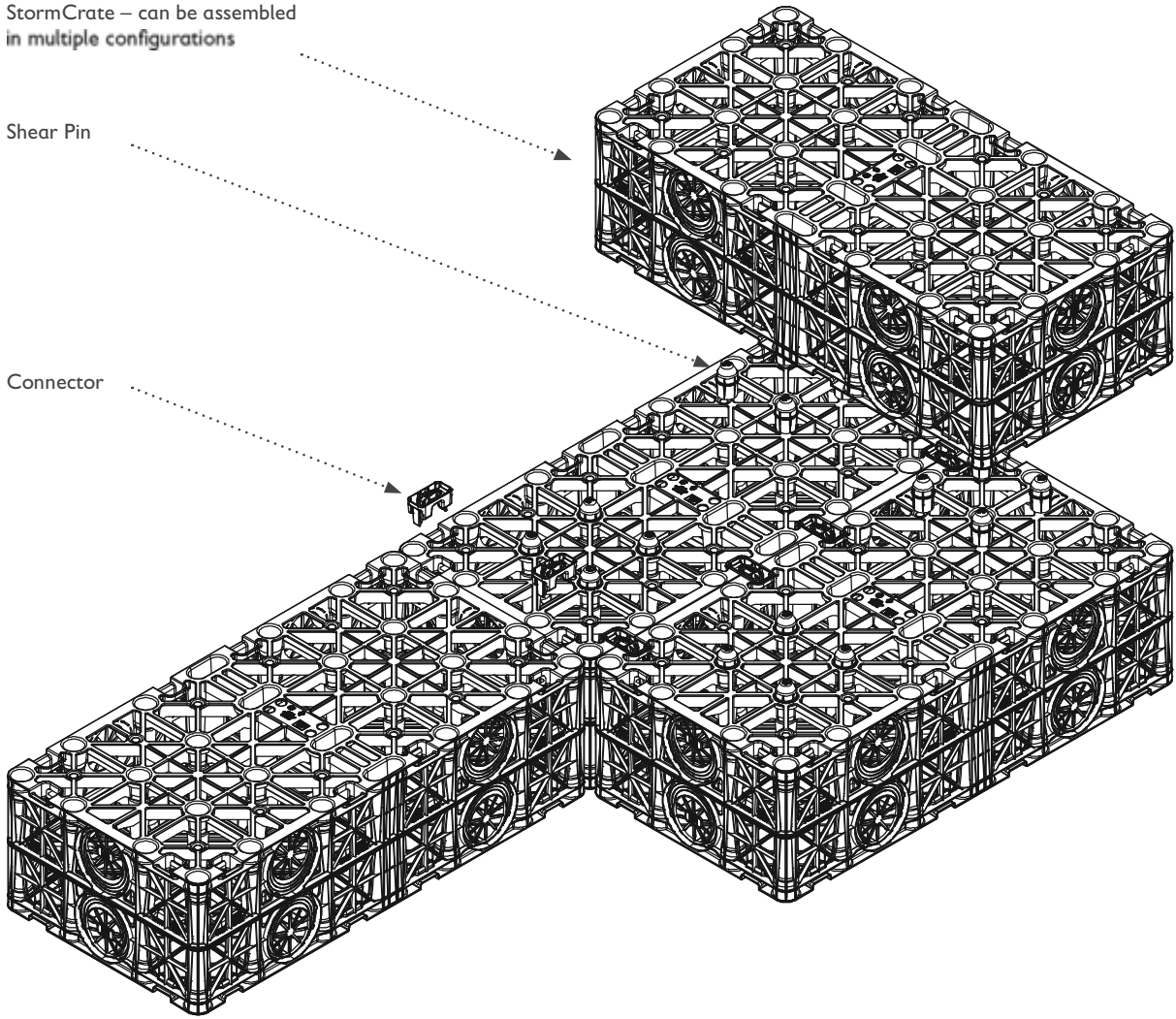

CONNECTING STORMCRATES

- During installation StormCrates should be securely fixed both laterally and vertically to ensure the overall structural rigidity of the system.
- Brett Martin StormCrates are securely joined together using purpose designed connectors and shear pins.
- This allows for easy assembly on site into a multitude of different configurations specific to the requirements of a particular site.
- StormCrates are designed to allow overlapping patterns which further increases the stability of the system by reducing the length of vertical joints in the tank.

Connector - for
connecting crates
together laterally.



Shear pin – for
connecting crates
together vertically.



- To connect StormCrates laterally simply place units side by side within the tank assembly so that the corners are aligned with one another and insert the connectors into the relevant slots.
- To connect StormCrates vertically place the unit on top of another either in the same orientation as the unit below or turned through 90degrees on the x-axis (brick bonding).

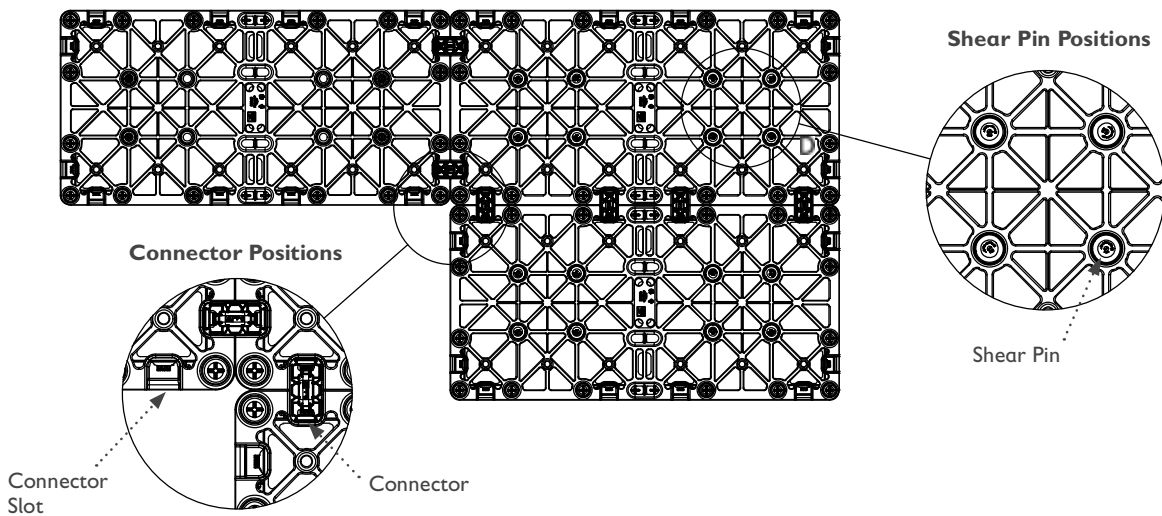
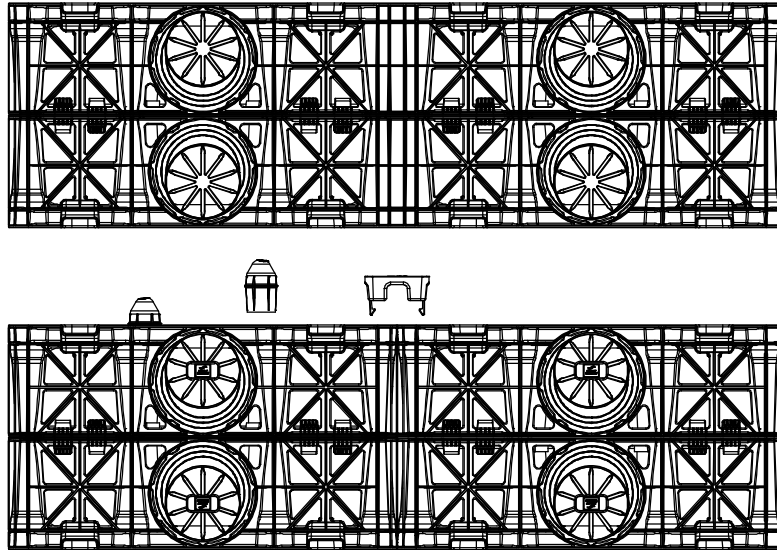

PRODUCT CODES

PRODUCT	PRODUCT CODE
Brett Martin StormCrate 0.25m ³	B8250
Brett Martin StormCrate Connector	B8251
Brett Martin StormCrate Shear Pin	B8252

TYPICAL APPLICATIONS

The Brett Martin StormCrate is a modular cell which can be combined with other Brett Martin StormCrates to form a single load bearing tank structure of any shape or size.

Designed for both trafficked and non-trafficked applications StormCrate will take a 56 tonnes per square metre vertical load and a 7 tonnes per square metre lateral load.

StormCrates are designed for use in both attenuation and infiltration applications. The high void ratio allows the system to receive rainwater, store and allow it to be slowly released back into the drainage system at a controlled rate or infiltrate into the surrounding ground.

StormCrate can typically be used in landscaped areas, pedestrian open spaces, domestic gardens, housing developments, driveways, carparks and commercial developments.

Suitable for both deep and shallow installations up to a maximum depth of 3m to base of units¹ (non- trafficked) from ground level (subject to site specific loading calculations).

Note 1 –

Assuming the following conditions:

- For infiltration systems serving an individual house
- Located below a garden a minimum of 5m from the building
- Inaccessible to motor vehicles
- Constructed in sandy gravels with a soil weight not exceeding 20kN/m³ and an angle of shearing resistance for surrounding soil not less than 30°
- Groundwater at least 1m beneath the base of the system.

TECHNICAL DATA FOR THE PRODUCT

PROPERTIES	VALUE	
PHYSICAL PROPERTIES		
Volume	0.25m ³	
Cube Storage Volume	0.2375m ³	
Void Ratio	95%	
Dimensions	1200mm x 600mm x 347mm	
Connections	12 x pipe inlets	
Weight	15.5kg	
Material	Polypropylene	
STRENGTH	VERTICAL	LATERAL
Short Term Strength	562kN/m ²	70kN/m ²
Long term Strength	153kN/m ²	19kN/m ²

Testing

As a large manufacturer of above and below ground drainage products, Brett Martin has both its own and the use of external testing facilities throughout Europe.

Types of testing explained

- **Laboratory testing**

In order to maintain a high level of product quality, Brett Martin products and materials are routinely tested under a strict testing and quality control regime.

This is completed to ensure that Brett Martin products are not only fit for purpose but exceed any relevant legislative or performance requirements.

- **Short Term Load Tests**

Short term load testing is completed at independent test houses. These tests are completed in both the vertical and lateral directions in order to derive the strength of the unit and also to select suitable loads for long term load testing.

- **Long Term Testing (Creep)**

Creep testing is used to assess the crates strength over time. In order to provide valuable creep data to our customers creep tests were completed at 27% of the of the short term compressive strength as assessed from the short term load tests.

These load tests were completed in both vertical and lateral directions for 220 days in order to accurately extrapolate the test data for a design life of 20 years.

Summary of test results

VALUE	VERTICAL	LATERAL
Short Term Strength ^a	562kN/m ²	70kN/m ²
Short-term Deflection ^a	1mm per 49kN/m ²	1mm per 6kN/m ²
Estimated Long Term Deflection Equation ^a	0.4126 Ln[time (hours)] + 2.0322 ^b	0.6263 Ln[time (hours)] + 0.3249 ^c

Note a at 23±2°C

Note b for loads up to 153kN/m²

Note c for loads up to 19kN/m²

- **Durability**

The extensive Creep tests were selected to allow for a design life of 20 years when the product is installed in accordance with Brett Martin's installation instructions. However, under certain design and installation conditions the crate may be capable of a 50 year design life, please refer to the Brett Martin Technical Department for further information.

- **Chemical Resistance**

Manufactured from Polypropylene, Brett Martin StormCrates are chemically stable and as such are suitable for contact with the chemicals which are commonly found in rainwater. For additional information on the resistance of Brett Martin StormCrates to particular substances please refer to the Brett Martin Technical team or the chemical resistance chart found at the back of this document.

Design protocol

- **Design Considerations**

When installing an attenuation system installers should ensure that they have selected a system with proven load capabilities in both the vertical and lateral directions.

It is essential that they ensure that the system is capable of withstanding the loads that it is likely to face when installed.

When designing an attenuation tank, designers should ensure that they fully understand the conditions of the site on which they are installing the system so that they can account for the soil properties, depth of cover and presence of any ground water. They will also need to fully understand the types of loading that the crate is likely to face.

These key factors mean that the installation design of a tank will vary significantly from one project to another.

- **Structural Design**

The structural design of a geocellular infiltration/attenuation system is covered under 5 main headings:

1. Derivation of the applied loads to the system
2. Summary of the laboratory testing completed on the StormCrate
3. Addition of partial factors of safety
4. Addition of safety factors to applied loads
5. Analysis of how the system will perform over its lifetime

DERIVATION OF THE APPLIED LOADS TO THE SYSTEM

Calculation of the applied loads requires careful consideration of the factors relative to each individual installation, CIRIA C680 and CIRIA C737 can be used for further guidance.

Once loads have been calculated the system designer should then compare these loads with the strength of the system using the Limit State Design philosophy.

Limit State Design:

The limit state of a structural drainage component such as the StormCrate is when the structure is in a condition where it no longer meets its design criteria.

Limit state design requires the addition of partial factors of safety to the strength of the unit, the loads applied to the system and the properties of the soil around the system. The purpose of these safety factors is to ensure a safe and functional structure.

Limit state design requires that the structure meets the criteria for both Ultimate and Serviceability Limit States.

Ultimate Limit State (ULS) – this is the point at which results in a structural failure of the system (e.g. collapse).

Serviceability Limit State (SLS) – this is the point beyond which the deflection criteria for the system are no longer met. The purpose of the SLS is to ensure that the deflection in the system does not result in damage to the surface of the ground above or result in the system no longer functioning correctly.

ADDITION OF PARTIAL FACTORS OF SAFETY

The characteristic strength of a StormCrate has been derived from 3rd party laboratory testing. However for in order to ensure total confidence in the geocellular structure the system designer should apply a material safety factor to the characteristic strength, this is known as the design strength.

The material partial factor takes into account a wide range of factors including:

- Manufacturing variability
- Extrapolation of test data
- Differences between the strengths mobilised under laboratory conditions and buried systems.
- Possibility of damage to products during installation.
- Environmental effects such as exposure to chemicals and temperature variability.

PARTIAL FACTORS OF SAFETY	
Limit State	Factor
Ultimate Limit State	2.75
Serviceability Limit State	1.5

ADDITION OF SAFETY FACTORS TO APPLIED LOADS

Similarly to the design strength of a unit the design load is derived by applying a partial factor of safety to the characteristic load. This allows for possible load variations in both the permanent and temporary works.

There are 2 types of loads which act on the StormCrate:

Permanent Actions – these are permanent loads such as the weight of backfill material over the tank.

Variable Actions – these are loads such as traffic loading.

Both permanent and variable actions can be either favourable or unfavourable.

Favourable loads actually benefit the overall stability of the system. An example of this would be the weight of backfill which is beneficial when analysing flotation forces due to groundwater.

Unfavourable loads are those which are not beneficial to the stability of the system for example permanent pressure from earth on the sides of the system.

NB: there is some discussion between different bodies concerning the safety factors between British Water, British Plastics Federation and CIRIA. As such installers should always satisfy themselves that the safety factors applied are both current and correct to the particular installation.

Load Factors

PERSISTENT AND TRANSIENT DESIGN SITUATIONS	PERMANENT ACTIONS		VARIABLE ACTION (UNFAVOURABLE) ¹
	Unfavourable	Favourable	
ULS – for stability and collapse checks			
Vertical Loads	1.4	1.0	1.6
Lateral Loads – Combination 1 in EC7 ²	1.35	1.0	1.5
Lateral Loads – Combination 2 in EC7 ³	1.0	1.0	1.3
Uplift	1.0	0.95	1.5
SLS – deformation and settlement checks			
All Loads	1.0	1.0	1.0

Notes:

1. Variable Favourable loads should have no partial factor applied.
2. To be used for assessing the unit's ability to withstand the applied lateral loads.
3. To be used to assess the overall stability of the ground and should only be used to assess the overall slope stability of overall stability of the units.

CIRIA Guidance

Further guidance on the design of geocellular attenuation and infiltration tanks including load calculations and safety factors can be found in CIRIA C680.

ANALYSIS OF HOW THE SYSTEM WILL PERFORM OVER ITS LIFETIME

This assessment will be used to prove whether or not the tank design is suitable for a particular application and covers the 4 main reasons for the failure of a geocellular system.

1. **Creep** – this is when the system deflects over time to an unacceptable level which leads to the failure of the system. This is caused by a constant load, for this reason a geocellular structure should only be installed when the long term loads are less than the loads used for creep testing. This means that a more accurate estimate of creep deflection for the system can be made.
2. **Structural failure** – this is when the applied loads are greater than that which the structure can withstand. It is vital that during the design of a geocellular system that the expected applied loads are known and accounted for in relation to the maximum loads which the StormCrate can withstand.
3. **Excessive deflection** – this is when the tank moves/distorts under loading beyond an acceptable level. This will often lead to cracking or subsidence of the ground surface above the system.
4. **Flotation** – when the groundwater table is above the bottom of the geocellular structure there will be an upward flotation force. It is essential that during the design phase that the level of the ground water table is adequately understood so that flotation forces can be considered as part of the design.

Maximum burial depths

The maximum installation depth of StormCrate depends on factors specific to each installation such as soil type, type of traffic etc. The table below shows some example burial depths.

TYPICAL SOIL TYPE	BULK UNIT WEIGHT OF SOIL kN/m ³	ANGLE OF SHEARING i°	MAXIMUM DEPTH OF INSTALLATION TO BASE OF UNITS (m)			
			Without groundwater below base of units (Normal Case)		With groundwater at 1m below ground level and units wrapped in a geomembrane	
			Non-trafficked areas ^[1]	Trafficked Areas (9,000kg GVW) ^[2]	Non-trafficked areas ^[1]	Trafficked Areas (9,000kg GVW) ^[2]
Stiff over consolidated clay e.g. London clay	20	24	2.18	2.18	1.79	1.79
Normally consolidated silty sandy clay e.g. alluvium, made ground	19	26	2.48	2.48	1.9	1.9
Loose sand and gravel	18	30	3.06	3.06	2.09	2.09
Medium dense sand and gravel	19	33	3.3	3.3	2.14	2.14
Dense sand and gravel	20	38	3.91	3.91	2.26	2.26

¹ – Landscaped areas where drive-on mowers are used in accordance with Table 4.2 or CIRIA Report C680.

² – Carparks: Cars or light vehicles up to 9000kg (GVW) in accordance with Table 4.2 or CIRIA Report C680.

- Calculations based on systems constructed from a single layer of StormCrate units.
- Weight of groundwater taken as 10kN/m³
- Angle of spread of wheel loadings taken as 27° in carparks with asphaltic surfacing and angle of internal friction of soil in landscaped areas taken as i°
- No account taken for accidental loading.
- Ground surface assumed to be level.
- Formation below system assumed to have adequate bearing capacity.
- Partial load and material factors are defined in CIRIA Report C680.

The maximum installation depth of a unit is very sensitive to the value selected for ϕ° it is therefore important that the installer has the selected value confirmed by a chartered geotechnical engineer.

It is also possible that the soil may loosen during installation and so the designer should be capable of allowing for this when selecting the ϕ° value.

Minimum Cover levels:

LOCATION TYPE	PEDESTRIAN AREAS	TRAFFICKED AREAS	
		GVW < 3,000kg	GVW < 9,000kg
Minimum depth of cover required (m)	0.5	0.6	0.75

The following assumptions apply:

- Calculations based on systems constructed from 1 layers of StormCrates.
- Soil weight and angle of internal friction have been assumed as 20kN/m³ and 38° respectively.
- Calculations based on there being no groundwater present.
- Angle of spread for wheel loads taken as 27° in car parks with asphaltic surfacing and angle of friction of soil in landscaped areas.
- No account is taken of accidental loading.
- Ground surface in vicinity of system to have assumed to be level.
- Formation below system assumed to have adequate bearing capacity.
- Installations greater than 4m deep require full calculations to be completed by a suitably qualified chartered engineer.

For some installations the depth of cover may need to be increased due to factors including the ground conditions or existing service/pipework already buried.

Inspection Chambers

It is recommended that an inspection chamber is installed on the inlet pipework of the StormCrate tank and prior to the inspection chamber should be a silt trap.

The silt trap should be routinely inspected and cleaned to ensure that the tank remains free from silt build up.

Connection for Infiltration applications:

When used for infiltration the site must be sufficiently permeable (which can be assessed using a percolation test) and also must have a maximum annual water table height of 1m below the base of the installation. The system will also be wrapped in a semi-permeable geotextile.

Base and Surround Material

Semi-permeable Geotextile Wrap

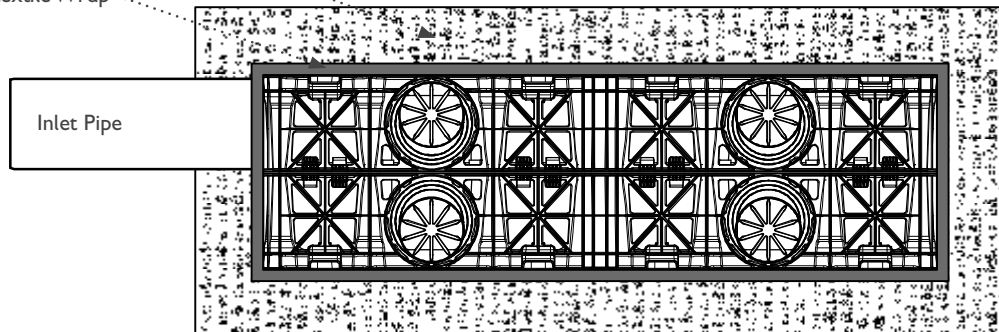

Inlet Connection for Storage applications:

When used for attenuation the system will be wrapped in an impermeable membrane in order to retain the water during a storm event so that it can then be discharged at a controlled rate after the storm through a flow control valve. Storage systems may be installed as an online system or an offline system.

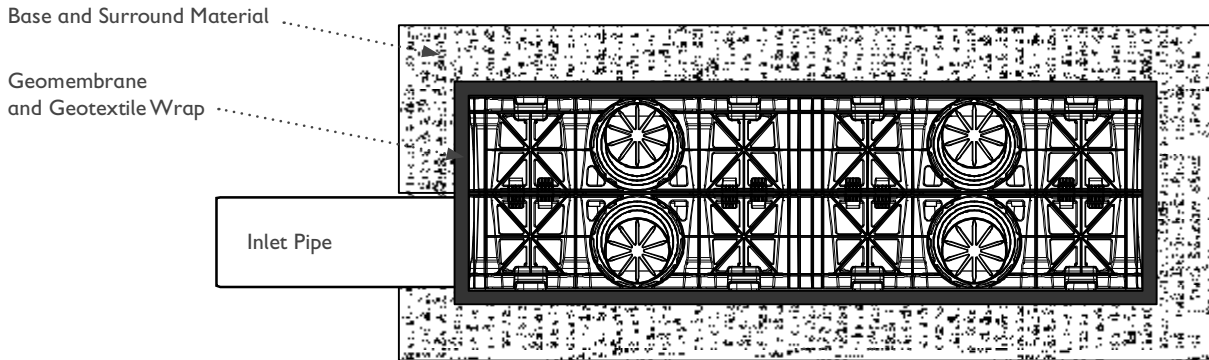

Example of an online solution.

Online storage solutions are connected directly to the main drainage system and will fill or partially fill each time water passes through the system.

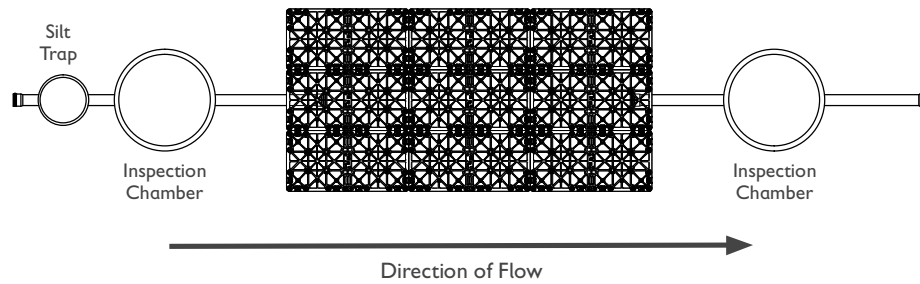

Example of an offline solution.

Offline solutions are separated from the main drainage system and only begin to fill when the demand on the main system is too high, they then release any stored water at a controlled rate back into the main system when the demand on the system is reduced.

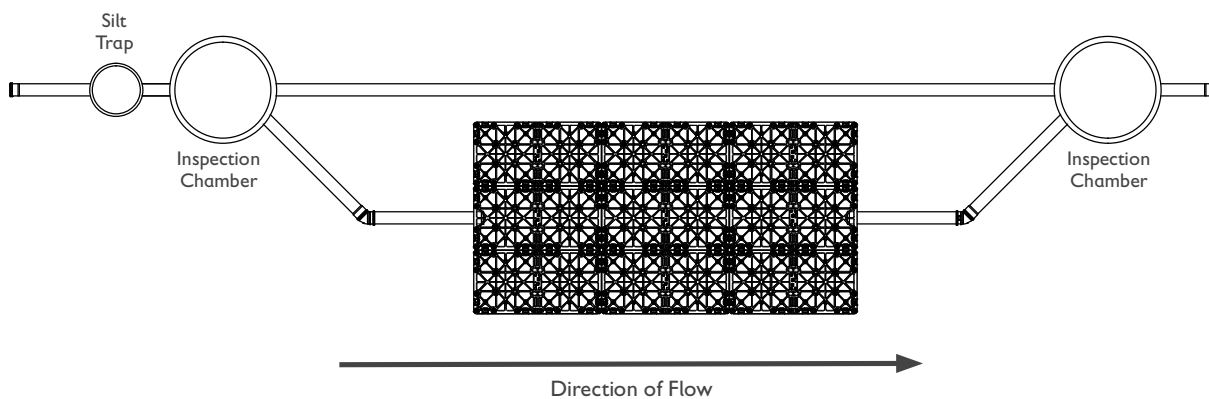

Connection Types for Attenuation:

There are 3 main methods of connecting incoming and outgoing pipework to StormCrates via control chambers each of which can be either online or offline type installations:

1. Central Pipe Connection:

When installed using an online central pipe connection the water will flow through the inlet chamber, into the half perforated pipe and through flow control valve in the outlet chamber.

During a storm when the half perforated pipe fills the water will begin to flow into the granular backfill material and fill the tank. Once the storm has ended the water will flow from the tanks through the granular backfill material and into the half perforated pipe into the outlet control chamber where it is released by the flow control valve.

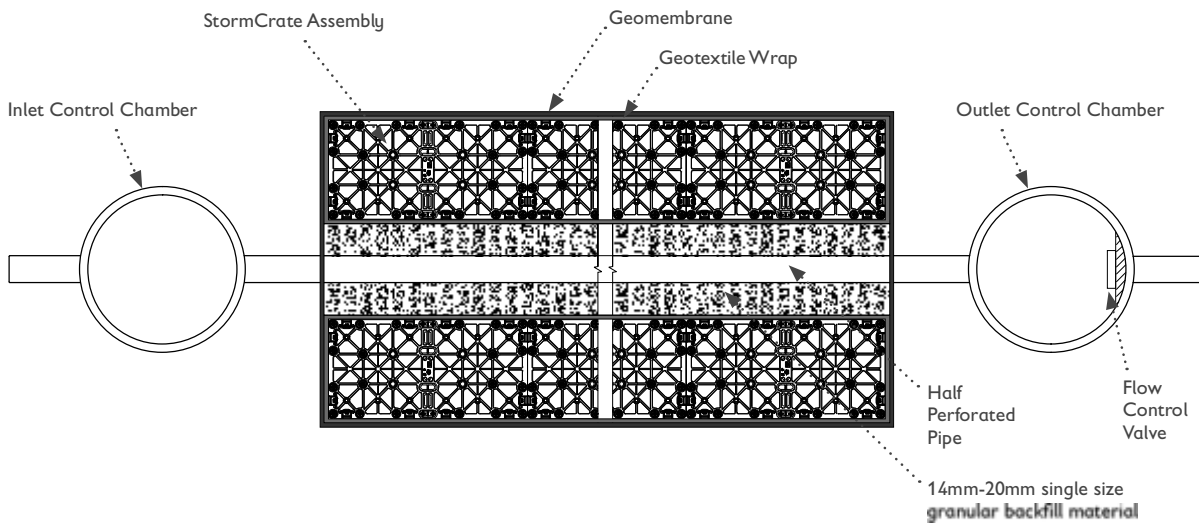

When installed using an offline central pipe connection the water will flow through the control chamber via the inlet pipe, flow control valve and outlet pipe.

During a storm the water level inside the control chamber will rise until it spills over the weir wall. Once this happens the water will flow into the half perforated pipe where it is dispersed into the granular backfill material and into the tank which will fill.

Once the storm has ended the water will flow from the tank, through the backfill material and back into the half perforated pipe where it is directed through the non-return valve in the weir wall, through the flow control valve and into the outlet pipe.

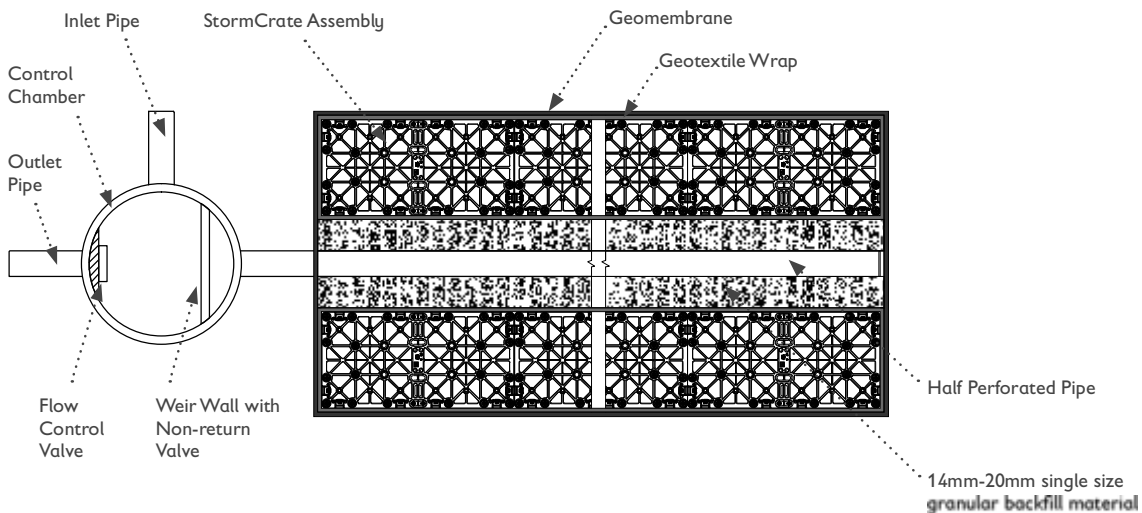

2. Manifold Connection

In an online manifold connection the water is able to flow through the inlet chamber, through the tank and out of the outlet control chamber via a flow control valve, during a storm the tank is able to fill. Once a storm has ended the water flows out of the tank via the flow control valve as normal.

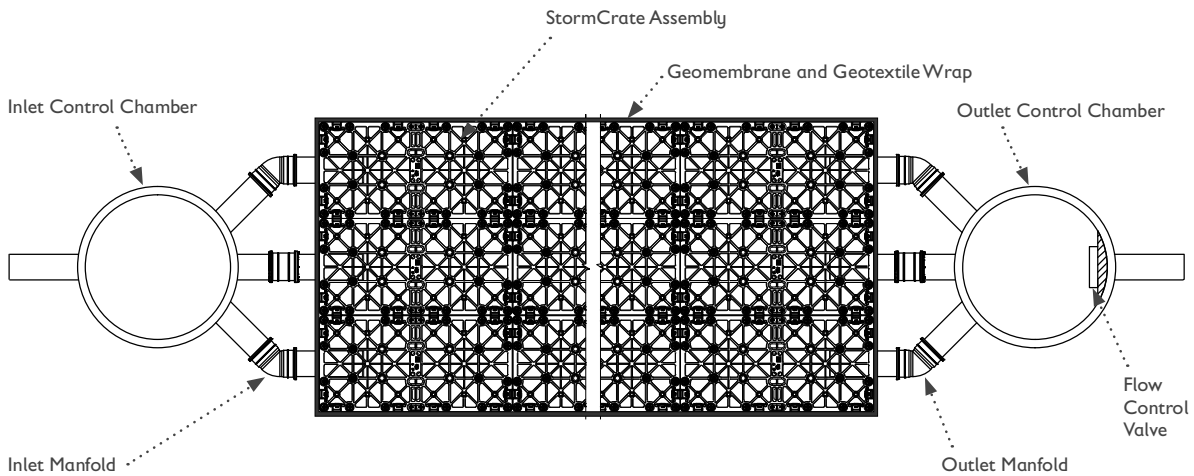

In an offline manifold connection during normal use the water flows into the control chamber via the inlet pipe and then is able to flow out of the control chamber via the flow control valve and outlet pipe. During a storm the water level inside the control chamber will fill with water until it reaches the top of the weir wall, once water is able to spill over the top of the weir wall the tank will begin to fill with water. Once the storm has ended the water will flow out of the tank through the non-return valve in the weir wall, through the flow control valve and out of the outlet pipe.

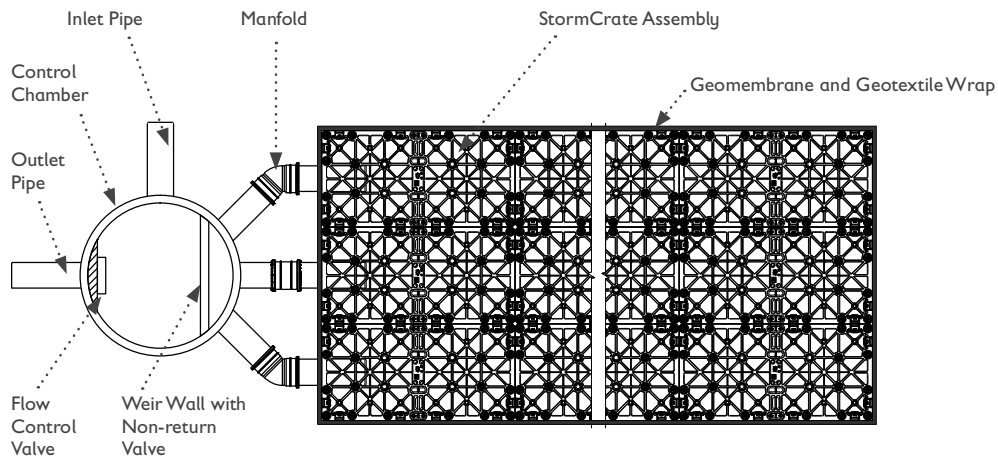

3. Box Connection:

In an online box connection the water is able to flow through the inlet chamber, through the tank and out of the outlet control chamber via a flow control valve, during a storm the tank is able to fill. Once a storm has ended the water flows out of the tank via the flow control valve as normal.

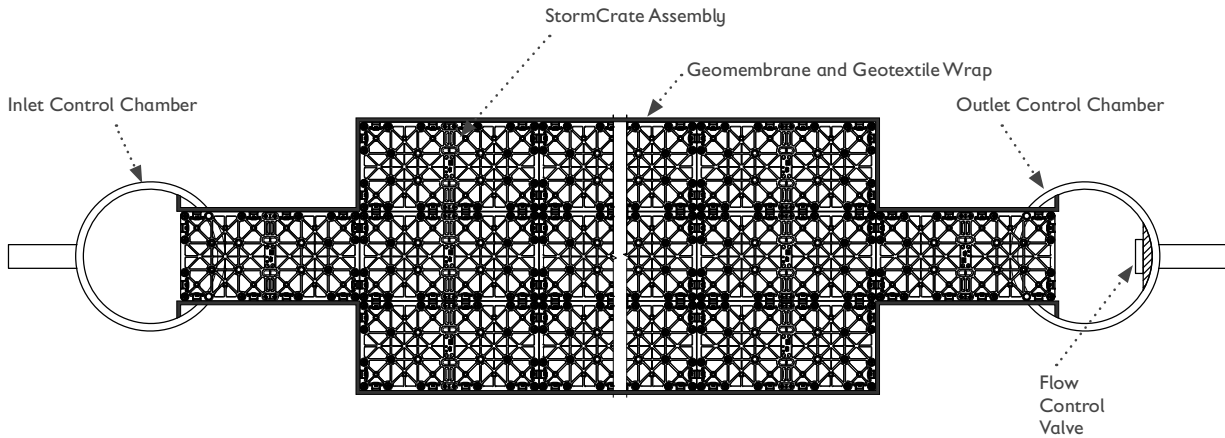

In an offline box connection during normal use the water flows into the control chamber via the inlet pipe and then is able to flow out of the control chamber via the flow control valve and outlet pipe. During a storm the water level inside the control chamber will fill with water until it reaches the top of the weir wall, once water is able to spill over the top of the weir wall the tank will begin to fill with water. Once the storm has ended the water will flow out of the tank through the non-return valve in the weir wall, through the flow control valve and out of the outlet pipe.

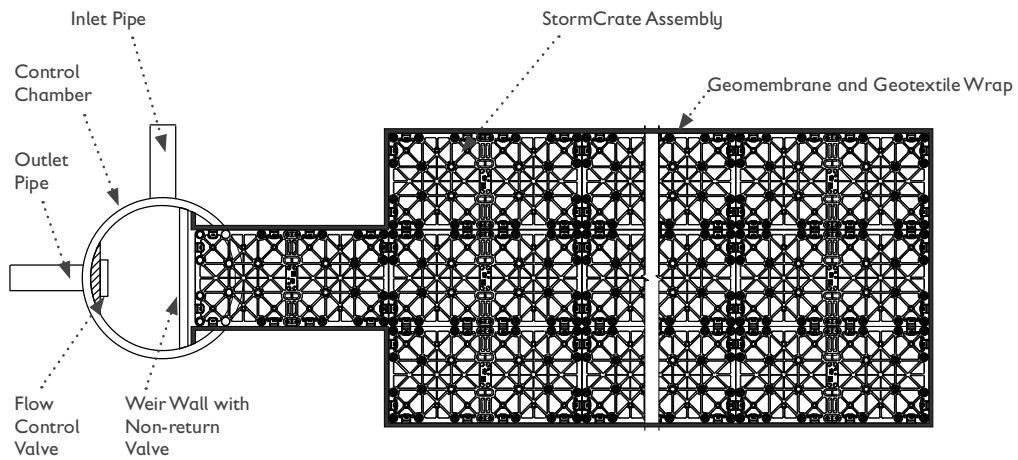

Typical Attenuation Installation Layout

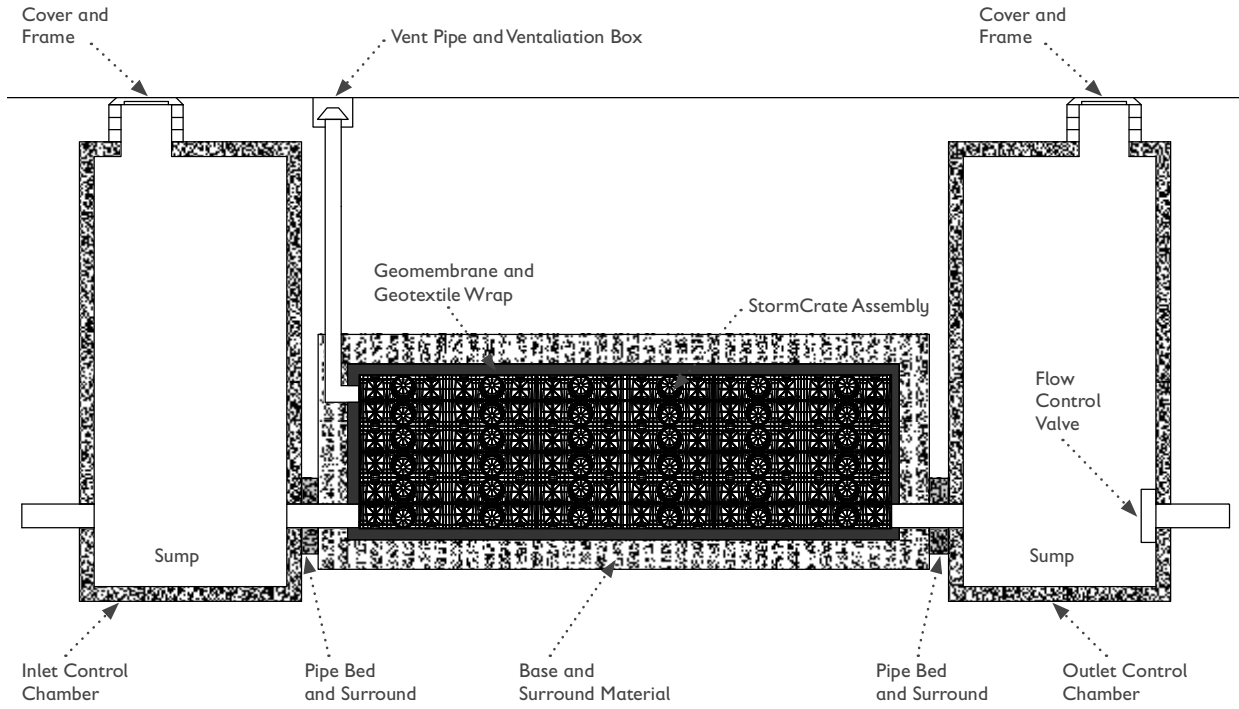

Lateral Load Relief

For some deeper installations or installations with increased ground pressure it may be necessary reduce the lateral load on the StormCrate Assembly. The simplest way to achieve this is to reduce the invert depth of the system, however where this is not possible there are alternative methods of reducing the lateral load.

- **Backfill material with a higher angle of friction** – specifying backfill material with a higher angle of friction will ensure that the earth pressure coefficient and in turn reduce the lateral load on the units.
- **Reinforced Backfill** – placing reinforced soil next to the units will help to reduce the lateral load. Backfill material can be reinforced with geogrids.

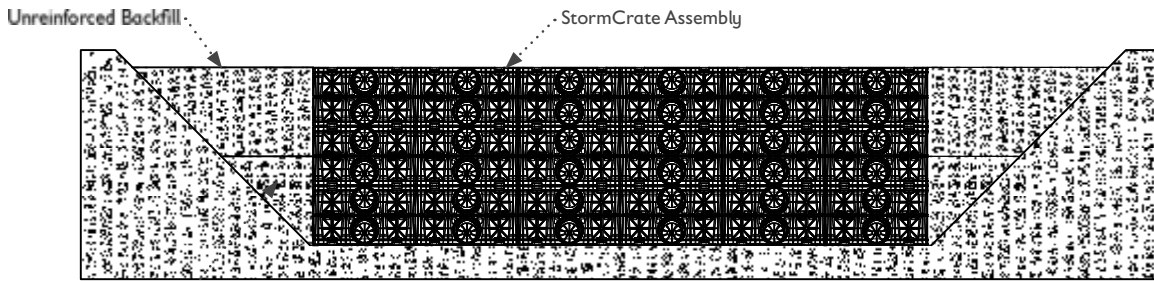

Reinforced Backfill

- **Concrete Backfill** – using a concrete backfill around the sides of the assembly will again reduce the lateral earth pressure on the system. However it is necessary to ensure that the system is capable of withstanding force applied to the system by the wet concrete until it has set.

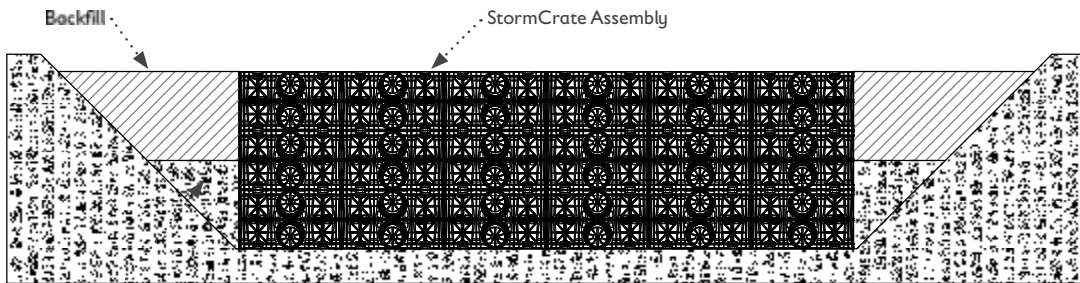

Concrete

- **Benching** – using benching and installing the units in a stepped configuration can lead to a reduced lateral load on the system. However it would be necessary to investigate the slope stability of the benches.

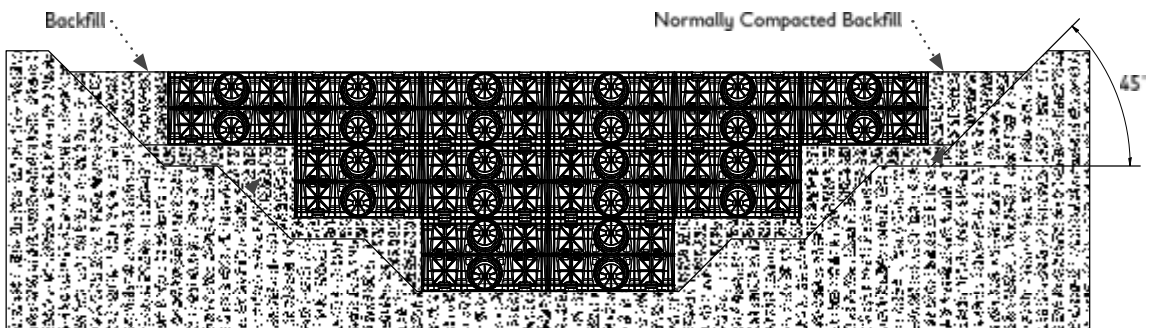

Benching

Highly Compacted Backfill

Hydraulic Design

StormCrates can be used for infiltration, attenuation or long term storage. These types of storage address three of the main priorities for dealing with water quantity required on site in CIRIA C753 The SUDS Manual, by directing runoff using infiltration, controlling peak runoff and controlling volume of runoff respectively.

Infiltration

StormCrates are installed to act as a soakaway tank. The tank provides a void underground, designed to fill quickly with water during rainfall events, and then infiltrate the water slowly back into the ground once the rain subsides, at a rate dictated by the ground conditions. This is usually the option most favoured by developers and building control, as water is dealt with directly at source.

Attenuation

StormCrates can also act as attenuation tanks. The crates create an underground chamber, designed to store and slow the peak flow during more intense rainfall events. This prevents large volumes of water from entering the drainage system too quickly. The water in attenuation tank is allowed back into the drainage system at an approved flow rate, usually agreed by the local authorities or at the greenfield runoff rate of 5 L/s.

Long term storage

StormCrates can also act as long term storage tanks. Working in a similar way to attenuation systems, the crates in this arrangement can provide a large amount of underground water storage, such as for a 1 in 100 year 6 hour design storm. This is designed to reduce increased total volume of runoff caused by a development, by storing excess water until it can be drained from site at a low flow rate or infiltrated back into the ground via soakaways.

Brett Martin StormCrates can hold water for attenuation or infiltration purposes, usually as part of a wider SUDS water management chain. The StormCrates have a 95% void ratio, enabling large volumes of water to be stored in a small amount of space compared to alternative underground storage methods. The volumes required for the attenuation or infiltration tank, and therefore the number and configuration of StormCrates required, depends on the ground characteristics, local weather, and site design. As each site is different, for an accurate estimate, all characteristics of the site need to be considered:

- **Local weather** – How much rainfall the site is expected to achieve in terms of average rainfall and heavy storm events will affect the number and configuration of StormCrates required.
- **Site design** – Catchment area size, additional SUDS components used on the site, proportion of impermeable surfacing and buildings, the specified outflow rate for the storage tanks, and any other pertinent information should all be considered to assess the requirements of the design.
- **Ground characteristics** – Soil type, bedrock type and slopes can affect how water behaves on site. Soil stability, protected features and nearby structures, water table height or water bodies can affect how underground tanks are used on site.
- **Volume required** – This is calculated using the above variables, to work out how much water enters the system over a time period (inflow), and how much water can leave the system over the a time period (outflow). The volume of storage requirement in the system is simply the difference between the inflow and the outflow. A ballpark figure for this volume can greatly help with concept designs and with checking the final figures.

I = inflow O = Outflow S = Storage required

$$I - O = S$$

As the design progresses, volumes and discharge rates for each SUDS components can be more accurately calculated and specified.

Local Weather

The SUDS should be able to manage storms up to the level required by the catchment area, discharge from site can be based on requirements from a 1 in 10 year storm event through to a 1 in 100 year storm event with an allowance for climate change depending on design requirements. Different areas of the country have different intensities of storms and rainfall. For outline designs and the initial planning stages of development, calculating the total storm rainfall expected on site can help determine overall storage requirements in expected worst case scenarios.

Rainfall information can be found by using FSR or FEH rainfall data models. Additional information such as Safety factors, Storm Return period and allowance for climate change should be considered and incorporated into the hydrograph data. This data is then used to assess the suitability and required sizing of the tank over a range of storm durations and intensities, in peak or critical conditions.

Site Design

Water behaves differently on different surfaces. Greenfield or planted areas allow rainwater to infiltrate into the ground and evaporate into the air, whereas water will run off hard surfaces like roofs, pavements and roads. The more rainwater that can be intercepted and infiltrated, the less volume required for water storage. In densely built up areas, larger storage volumes may be required. Sewers for adoption recommends that 100% water landing on impermeable areas be considered as runoff in volume calculations. Outflow rate is, in most cases, specified by the local authority, which will influence attenuation storage requirements.

Brett Martin StormCrates can be used to store small or large volumes of water, for a short duration or long term. They can be installed underneath landscaped areas, pedestrian and light traffic areas and also under heavily trafficked areas. As these tanks usually contain the water which hasn't been stored elsewhere on site, they are usually positioned by the lower outflow, and as such, are usually the first SUDS component to be installed. Phasing of site development can dictate a different installation order, requiring temporary water storage until the StormCrates are installed.

The site survey and desk survey will have revealed the best location for the tanks, and any constraints to the tanks' footprint. Brett Martin StormCrates can be installed in a variety of configurations to achieve a wide variety of required volumes and footprints.

Ground Characteristics

SUDS are designed to mimic the natural drainage processes of a site. Post-development outflow volumes and flow rates should match pre-development drainage volumes and flow rates. Flow rates of a site are often calculated using gauged (metered) flow rate data, or by comparing the site to similar known sites.

For infiltration systems, the infiltration rate of the ground has the largest influence on how much storage volume is required. A desk survey can indicate the possible permeability of the ground and whether infiltration is likely to be successful or not. On-site soil-type testing is useful at the concept design stage to gain a rough idea of how permeable the soil is. For more accurate volume calculations, on-site percolation tests are invaluable for finding specific infiltration rates at the site of the SUDS and determining whether larger or smaller tanks are necessary. BRE Digest 365 outlines the standard percolation test.

It is advised that all soakaways should have 1m of unsaturated soil beneath them to ensure efficient infiltration into the surrounding ground. Similarly when designing attenuation tanks, ground water level should be considered to ensure that flotation of the tank does not occur. This is so the tank can operate to optimum efficiency.

Infiltration Tank Size - General Estimate

Infiltration tanks must be sited on ground suitable for a soakaway. If the suitability of ground conditions are not known a soil-type test and/or soil percolation test should be conducted to assess whether or not the ground is permeable enough for a soakaway.

Building Regulations 2010 part H3 gives guidance on estimating a basic soakaway size. This calculation is only designed to be used for areas of 25m² or less, and assumes a lesser flood risk, so a 10mm depth of rainfall over the area to be drained is used. e.g. for a catchment area of 25m², the required volume would be 25m² x 0.01m = 0.25m³.

Larger or more complex projects require more in-depth calculations. In these situations, the methods in BRE digest 365 and CIRIA R156 should be used to assess volume requirements against a range of storm durations and intensities. From these calculations, the greatest storage volume required on site can be identified and flood risks managed appropriately.

Estimate vs Real Life

The storage volumes calculated above are the minimum effective volumes estimated to be necessary. The volumes are based on statistically probable storm intensities and durations, and the most likely maximum storage required. Very occasionally, storms will occur with greater rainfall than this and so very occasionally the tank may overflow. This extra water needs to be assessed for risk, and be accommodated either in a larger storage volume, or through other outflows built into the SUDS system, or by the site.

Infiltration Tank Size - Accurate Estimate

For larger or more complex sites than those mentioned above, or for a more accurate estimate of soakaway size, the methods in BRE digest 365 and CIRIA R156 should be used. These methods use infiltration coefficients of the ground, together with a range of design storm durations and intensities, to assess soakaway volume requirements. From these calculations, the greatest storage volume required on site can be identified and flood risks managed appropriately. Brett Martin can help with these calculations, if provided with an on-site infiltration co-efficient. To find the on-site infiltration coefficient use either the CIRIA R156 table, or the BRE digest 365 soil percolation test, both outlined on the next few pages.

Soil types for infiltration

Determining the type of soil on site can help establish whether infiltration is likely to be successful or not. The infiltration coefficients from CIRIA R156 are shown below for the different types of soil, these can be useful for calculating ball-park volumes at concept and outline design stages.

	INFILTRATION RECOMMENDED	SOIL TYPE	INFILTRATION COEFFICIENT (m/hr)
Good infiltration media	Yes	Gravel	10 - 1000
		Sand	0.1 - 100
		Loamy-sand	0.01 - 1
		Sandy-loam	0.05 - 0.5
Poor infiltration media	Possibly	Loam	0.001 - 0.1
		Silt-loam	0.0005 - 0.05
		Chalk	0.0010 - 100
Very poor infiltration media	No	Sandy clay-loam	0.001 - 0.1
		Silty clay-loam	0.00005 - 0.005
		Clay	<0.00001
		Till	0.00001 - 0.01
		Rock	0.00001 - 0.10

For a more accurate, site specific, infiltration coefficient, a soil percolation test is necessary. This is summarised below. See BRE Digest 365 for more details.

BRE Digest 365 Soil Percolation Test

To obtain a more accurate infiltration coefficient in the location that the system is to be installed, the BRE digest 365 soil percolation test is the recommended method that should be used to obtain this figure. The test method is as follows:

1. Dig a bore-hole or trial pit, to the same depth as the intended soakaway, 1m - 3m long, and 0.3 - 1m wide, with vertical sides. For safety reasons, do not enter the pit.
2. Fill the pit with water to the design invert level of the drain to the soakaway.
 - Water levels can be monitored by eye or with a dip tape.
 - Fill the pit quickly to mimic the effects of a storm.
 - A lot of water will be used for this, so a water bowser may be required. Note the water level and time when full.
3. Let the water drain away until the pit is nearly empty.
 - As the water is drained, note the water level and time at several intervals.
 - This will enable a relationship to be seen between time and water depth which can be used in the hydrology calculations.

4. Fill the pit and measure the outflow two additional times. Ideally, this should all be completed on the same or consecutive days.

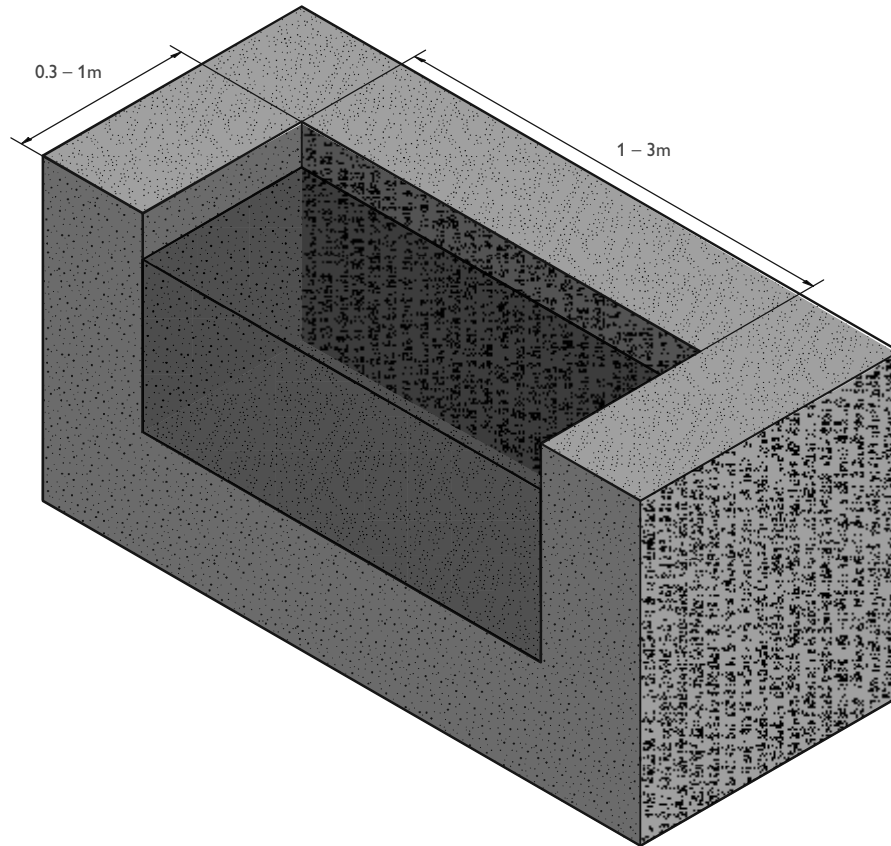

5. Produce three graphs of time versus water level (a typical example is shown below).

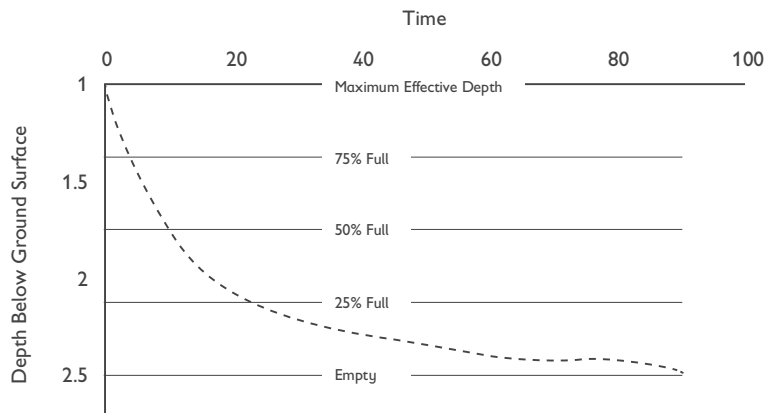

6. The soil infiltration rate can then be calculated as follows:

$$f = \frac{V}{a \times t}$$

Where:

f – soil infiltration rate (m/s)

V – volume of water between the 25% full mark and the 75% full mark (m^3)

a – the internal surface area of the bottom 50% of the pit including the base (m^2)

t – time taken for the water to drop from 75% to 25% full (s)

The soil infiltration rate, f , used for the design of the SUDS is the lowest value derived from the 3 tests.

If the intended infiltration area in the finished development is large, long (greater than 25m), or passes through several different types of ground or soil, then further test pits will be required. This is because infiltration rates can vary a lot across a site, so more test pits will help create a more accurate picture of actual site conditions, and allow the optimisation of the proposed SUDS design.

NB: All volume calculations are based on accurate statistics of likely rainfall and conditions. In the real world however, it is very likely that at some point, the system will be faced with more rain than it can handle. Design for exceedance is very important in SUDS. This often takes the form of greater storage volumes on site or provision for overflow.

Infiltration Tank Size Calculations

Using the soil infiltration rate found from either the CIRIA R156 coefficients discussed previously, or the BRE Digest 365 Soil Percolation Test, the volume of the infiltration tank can be estimated more accurately. Brett Martin will be able to help calculate this volume based on the infiltration coefficients for your site.

Using the soil infiltration rates for the site, Brett Martin can estimate the volume of crates required.

Rainfall Map of the UK

The map below shows the rainfall depths across the UK for a 1 in 100 year design storm, with a duration of 6 hours. The location of the site and the associated rainfall depths can be used in calculations to determine the infiltration or attenuation tank volume.

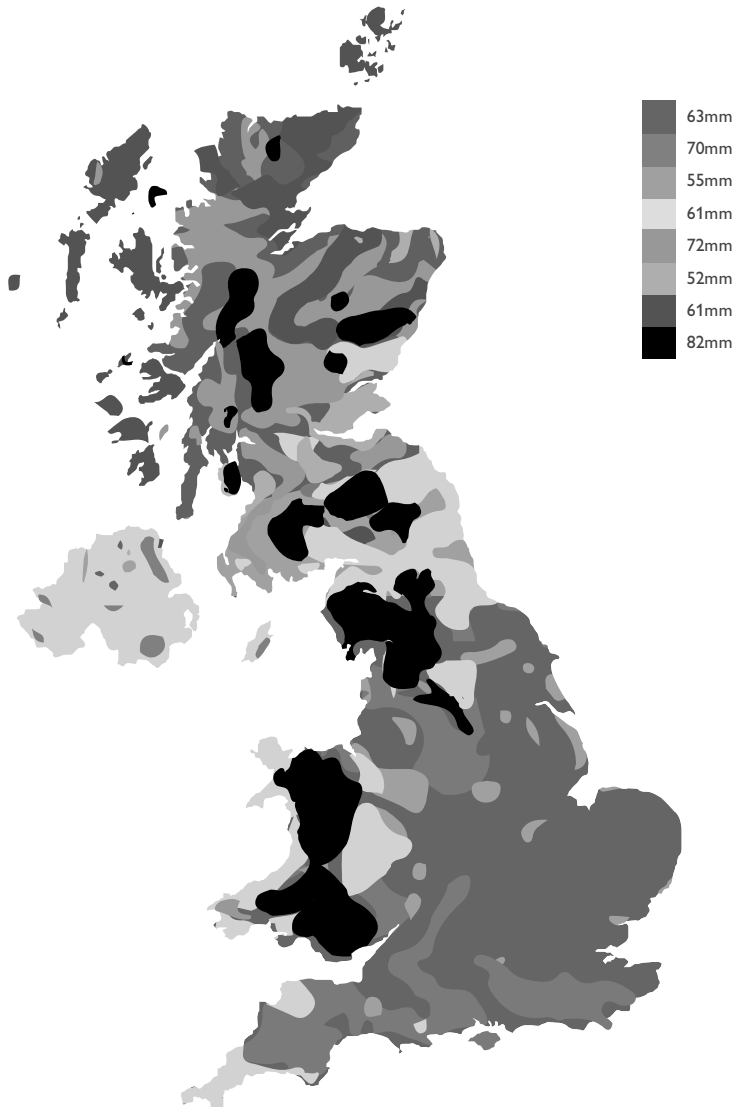

Siltation

Siltation can have an adverse impact of the operation of a tank, particularly on soakaway installations by reducing the infiltration efficiency. All StormCrate systems should be designed with provision for silt interception. Most commonly this will be a silt trap installed upstream of the tank in order to remove the majority of silt before entering the tank. Other methods such as filters or permeable paving can also be used to intercept silt. If excessive silt does get into a tank then it is difficult to remove and can reduce the overall capacity and performance of the tank. A typical silt trap is shown below.

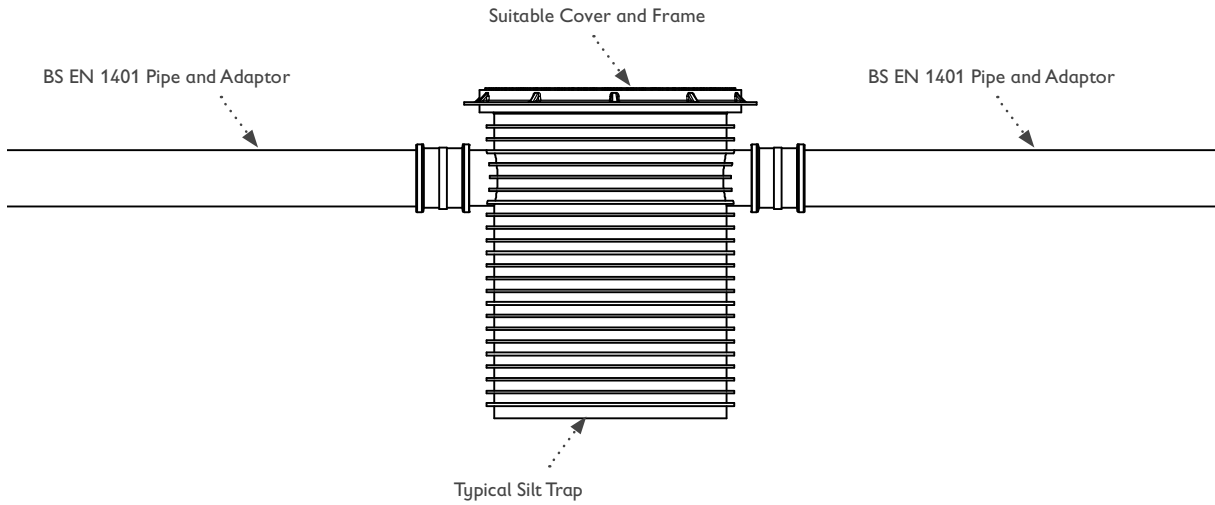

Location Options

When designing any geotechnical structure such as an Attenuation or Infiltration tank using Brett Martin StormCrates it is important that the location of the system relative to other structures/earthworks is known.

These structures can impose significant and complex loads on underground structures and so it is preferable to modify the location of an installation to avoid these interactions rather than completing a complicated analysis to assess the long term effects of these adverse loading conditions.

Some relevant structures/earthworks may include:

- **Building foundations** - loading from the building may be imposed on the system if insufficient space is left between the building and the installation. Additionally the designer must ensure that the system does not have a negative effect on the building, this can be caused by:
 - Percolating water damaging the foundations due to the system being installed too close to the building (StormCrate should not be installed within 5m of the building structure).
 - Excavations during the installation phase undermining the building foundations as a result of the system being installed too close to the building.
- **Slopes** – these can impose shear loads on StormCrate assemblies and so it is important that a slope stability analysis is completed if the system falls inside the slope's zone of influence.
- **Trees** – the zone of influence of a tree should be fully understood before installation can be commenced:
 - Trees impose large permanent loads on underground structures within their zone of influence.
 - Roots can spread by up to 1.5 times the height of a tree and so this should be allowed for before the location for installation is chose, growing roots can damage the membrane and even grow through geocellular installations.
 - Care should be taken during excavation as damage to roots caused during excavation can destabilise the tree.

Assessing whether a StormCrate assembly falls into the zone of influence of a structure/earthwork should always be carried out on a site by site basis. The designer should always seek judgement from an experienced professional as to how the location should be moved or the effect of the structure on the StormCrate assembly.

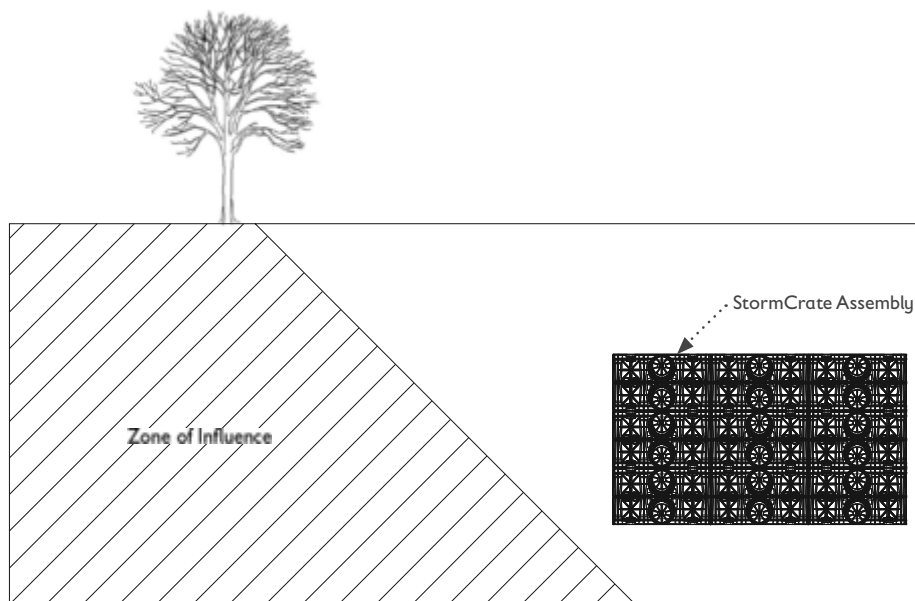

Installation

The installation of a Brett Martin StormCrates tank, will depend on the final intended use. Crates used for infiltration will use different accessories and installation practices to those used for attenuation. Although each site and use is different, much of the pre-installation checks and preparation work will be identical.

Preparation

Before installation, ensure contractors are aware of the function, precautions and installation procedures for the Brett Martin StormCrates and their place within the site's SUDS water management train.

This is important because if actual found conditions on site require changes to the plan, as often happens, then any changes to the SUDS system as a whole could impact on the StormCrates installation, and any changes to the StormCrates installation could impact on the whole SUDS system. It is important that any changes, including levels, layout and materials, are checked by the designer before implementation.

For SUDS to work well, careful construction is required, including accurate levels for inlets, outlets and component bases, and even, **smooth and horizontal fill layers.**

Protection of the StormCrates and Membranes during storage and construction is vital to ensure they perform as required after handover.

Geotextiles and Geomembranes should be fitted by a skilled worker with an NVQ or equivalent in membrane installation, as advised in this installation instruction and according to the manufacturers fitting guides. Brett Martin StormCrates should be fitted according to the installation instructions below and according to the Design Drawings.

Ensure all necessary permissions and licenses have been granted if working on or near protected or contaminated areas or features.

Pre-Installation Checks

- Ground levels, groundwater levels, and ground conditions on site match those described in the report
- **On-site locations of any underground utilities confirmed using exploratory pits**
- Required protection is in place for any protected areas, features or public access
- **Excavation area has sufficient access around it for appropriate plant**
- Plant access to the rest of site can avoid this area once StormCrates are installed
- **Infiltration areas have been isolated from plant or stockpiles that could over-compact it**
- **Products supplied are as stated in the Design documents specification and are in good condition and free from defect or damage**
- **Tank Configuration Construction Drawings, including invert levels and pipe arrangements, silt traps, outflow regulators, inspection chambers etc are to hand**
- Installation Instructions are to hand
- Timetables and milestones for inspections and checks have been agreed

Also see the Construction Method Statement (CMS) for the works and the site Health & Safety Assessment. Further information can be found at CIRIA C768 – Guidance on the Construction of SUDS, and CIRIA C753 – The SUDS Manual.

Typical Installation Procedure

Best practise for the installation for the StormCrates is below. Also ensure that the Design Drawings, the Design Report, and the Construction Method Statement for the particular job is followed.

Standard industry tolerances for levels and dimensions are acceptable in most cases. Wide tolerances could impede the flow of water and compromise the system so the more accurate the levels the better.

Excavate

- Excavate to the required plan dimensions.
- **Mark the extents of the StormCrates installation and then allow an extra 300mm to 500mm for backfill and any supporting underground structures.**
- Mark the positions of accompanying ancillaries – pipework, chambers etc.

- Ensure access slopes, steps, and sides are safe and that measures are in place to protect the excavation from silty or muddy wash out from site. Brett Martin StormCrates are quick and easy to install, limiting the length of time the excavation is open, thereby reducing the amount of time that protective measures need to be in place. Two points of access would be ideal.
- Make the base of the excavation level, smooth, and free of sharp objects. The base for the tank requires the most stringent tolerances, typically $\pm 20\text{mm}$ over 3m. Replace any soft spots with compacted granular material to provide uniform support for the crates and membranes. This will reduce uneven or excessive stress on the crates.
- Protect and barrier the excavation as appropriate, with appropriate signage for vehicles and pedestrians.

Bed

- Create a drainage bedding layer for the StormCrates of permeable fill, levelled and compacted appropriately.

Geotextiles and Geomembranes

- Line the base of the excavation with membrane, with sufficient allowance for welding overlaps. This is usually 300mm, but installers should refer to the manufacturer's requirements.
 - For attenuation tanks line the excavation with protective geotextile and then with impermeable geomembrane.
 - For infiltration tanks, line the excavation with a geotextile suitable for infiltration.
- Minimise walking along the surface of the textile/membrane in order to prevent damage.
- Check the membrane both before and after installation for punctures or tears. If the membrane is damaged, patch it at least 400mm wider than the extent of the damage, or according to the manufacturer's instructions. Follow advice from the geotextile manufacturer regarding protective measures and proprietary requirements.
- Weld the seams according to the manufacturer's instructions.

First Layer

- Lay out the first layer of crates on top of the membrane(s) as per the construction drawing. Installing a complete layer of crates above the membrane(s) helps to protect the membrane(s) during the rest of the installation.
- Arrange the crates so that their orientation allows easy connection to the adjoining pipework.
- Securely connect this first layer of crates together using the connectors (Product Code – B8251).
- Check correct assembly, alignment and connection of the crates and check outlet levels.



Adding additional layers

For some installations, StormCrates will be installed in multiple layers. For these installations:

- Build up the crate assembly using further crates according to the construction drawing. Use the connectors to secure the crates together horizontally and use the shear pins (Product Code – B8252) between layers.
- If using two or more layers, brick bond the crates for extra stability.
- Keep storage stacks of crates to a maximum of eight high for safety.
- Individual crates are light and easy to handle, so shouldn't require movement by plant. If movement by plant is necessary, ensure it keeps a safe distance away from the excavation, and that tanks are assembled by hand.
- Check correct assembly, alignment and connection of the crates, and check pipework levels. It is important to keep the area free of dirt and debris. These cause siltation and blockages, compromising the **functionality of the finished tank.**



Pipework

- To connect 110mm pipework, knock out the end circle of the appropriate crate so that the pipework can be joined, and insert adaptors as necessary. Only one knockout should be removed from a crate.
- **To connect any other sizes of pipework use top hats joined to the side of the crate without removing the knockouts and fit on the panel next to the knockouts as this panel will allow the most water through.**
- All pipework installed should be designated SN8 or higher.
- While the work is being completed, use bungs in the connecting pipework to prevent siltation and water entering the structure during works.
- Seal the pipes to the crates in line with the contractor's method statement.
- Seal the membrane around the pipes.

Ventilation

Every attenuation tank requires at least one vent to avoid the risk of water becoming stagnant and ensure maximum hydraulic performance.

- **Attach vents using a flange adaptor which should be securely fixed to the tank using cable ties.**
- **After the membrane has been wrapped, seal the membrane around the flange using the same procedure as for sealing around pipes. Insert the vent pipe.**

Typical installation information for vents can be found later in this document.

Wrap the Membrane

- Continue to wrap the membrane(s) around the crates, using the appropriate overlap.
- **For both attenuation tanks and infiltration tanks weld the joins, as per the manufacturer's instructions and to CIRIA SP124, until the tank is completely encased.**
- Make allowances in the membrane for pipework and ventilation pipes, and seal the pipes to the crates in line with the contractor's method statement.
- Test all sealing equipment regularly to ensure consistency throughout the installation
- It is important to keep the area free of dirt and debris as these cause siltation and blockages, compromising the **functionality of the finished tank.**
- **Also, keep the area dry to prevent tank floatation. The tanks are very light and can float on just a few mm of water, which may affect levels and cause damage to the crates or membrane.**
- Once connected, test all seals for leaks in accordance with the contractor's method statement and/or to CIRIA SP124.

Backfill around the sides

- Once the crates are installed and wrapped, backfill around the sides of the crates and compact appropriately.
- It is important to build up each layer of backfill evenly, taking care not to put any asymmetric lateral force on the crates.

Backfill on the top

Check the integrity of the membrane(s). Then above the wrapped cells, place and lightly compact a layer of coarse sand. Further backfill types, depths and compaction above the crates depends on the expected operational loading above the crates. The greater the depth of fill above the crates, the greater the load they can bear. For efficiency, light plant filling the first layer, can be followed progressively by heavier plant filling each additional layer, see illustration below.

Plant should never be used directly on top of StormCrates and should only be used when an adequate layer of backfill has been laid to ensure that damage is not caused to them. All necessary design calculations should be completed to ensure that the level of backfill is suitable for the type of plant being used at that point.

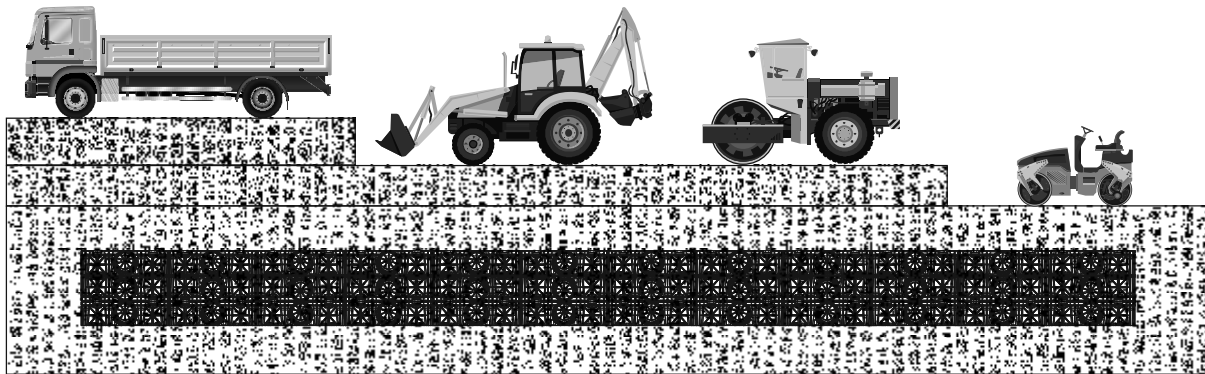

Checks

Once installation is complete the system (including any control chambers or silt traps) should be inspected to ensure that it is clear of silt and debris.

It is recommended that during the construction phase that the tank is bunged off to isolate the tank thereby minimising the risk of debris or siltation until construction is completed. Once the site is complete the bungs can then be removed.

Treatment

- Rainwater from roofs and gutters does not need to be treated and can drain directly into infiltration tanks.
- Rainwater from carparks and trafficked areas carries pollutants, which must first be treated to avoid the ground and surrounding water courses becoming contaminated by them. A catch pit manhole or petrol interceptor can be used to treat this water before it enters any infiltration system.

Maintenance

- Both attenuation tanks and infiltration tanks require some maintenance. Maintenance is the responsibility of the customer.
- For crates installed in individual houses, gullies and inlets should be kept clear of debris and leaves.
- For larger installations, a system of regular inspection should be established to prevent siltation of the system which if allowed to develop, would reduce its effectiveness. Inspect and clean both the crates and the silt traps.

Summary Installation guide

- Excavate to the required depth with a base which is slightly larger than the plan area of the StormCrates.
- Create a 100mm thick bed, level and compact.
- Place a permeable geotextile (for infiltration) or a protective geotextile and impermeable geomembrane (for attenuation) into the trench allowing enough material for wrapping and joining.
- Build the first layer of crates utilizing the StormCrate connectors
- Begin adding additional layers as required utilizing both the brick bonding pattern and shear pins.
- Add the necessary pipework.
- Add adequate ventilation for attenuation tanks only.
- Wrap the membranes and textiles around the tank ensuring that the welds are secure and tested.
- Create a 100mm thick backfill around the sides of the tank using coarse sand or class 6H granular material and fill any remaining space using a standard structure fill of class 6N or 6P, or natural gravel of less than 75mm granule size.
- Create a 100mm thick backfill on the top of the tank using coarse sand or class 6H granular material and backfill any additional space using the appropriate backfill for the type of traffic involved.
- Ensure that water treatment is included in any infiltration system draining water from car parks or trafficked areas.

Ventilation (Typical Installation Information)

Vents can either be fitted to the top of the tank using a flange adaptor or to the side of the tank utilizing one of the unused inlets (**NB:** the connection between the pipework and the tank must be sealed).

If the using a side entry vent then the expected fill level of the tank must be lower than the selected inlet position.

The recommended number of vents is typically one for every 7500m² of impermeable catchment area.

Top Connection:

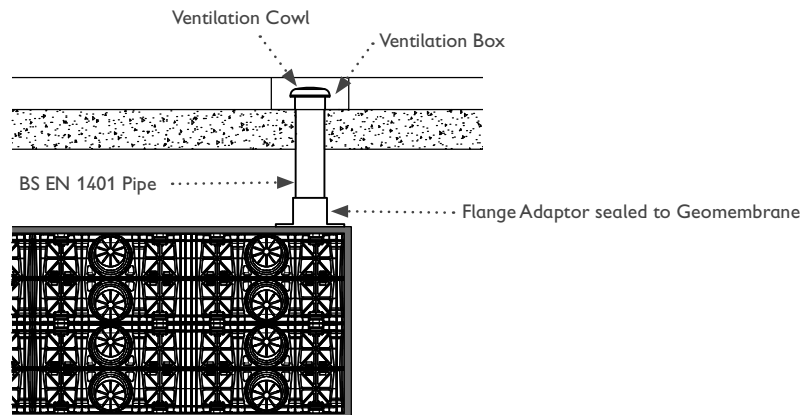

Side Connection:

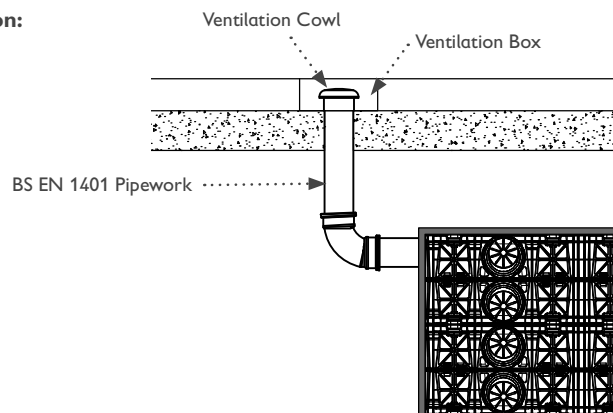

Chemical Resistance Chart

The below table shows the general resistance of Polypropylene to a variety of chemicals, however factors such as temperature, time, concentration, duration and mechanical load will all affect the resistance of a material to a chemical.

AGENT	CONCENTRATION (WEIGHT %)	POLYPROPYLENE (HOMOPOLYMER)	AGENT	CONCENTRATION (WEIGHT %)	POLYPROPYLENE (HOMOPOLYMER)	AGENT	CONCENTRATION (WEIGHT %)	POLYPROPYLENE (HOMOPOLYMER)
Acetic acid, aqueous solution	5%	+	Glycerine	-	+	Potassium permanganate, aqueous solution	1%	+
Acetic acid, aqueous solution	10%	+	Glykol	-	+	Propanol	-	+
Acetic acid, concentrated	-	+	Glysantin, aqueous solution	40%	+	Pyridine	-	0
Acetone	-	+	Heating oil	-	0	Silicone oils	-	+
Ammonia solution	10%	+	Heptane, Hexane	-	+	Soap solution, aqueous solution	-	+
Anone	-	+	Hydrochloric acid, aqueous solution	2%	+	Soda lye, aqueous	5%	+
Benzene	-	0	Hydrochloric acid, aqueous solution	36%	+	Soda lye, aqueous	50%	+
Benzine	-	0	Hydrofluoric acid	40%	+	Soda solution, aqueous solution	10%	+
Bitumen	-	0	Hydrogen peroxide, aqueous solution	1%	+	Sodium bisulphate, aqueous solution	10%	+
Boric acid, aqueous solution	10%	+	Hydrogen peroxide, aqueous solution	30%	+	Sodium carbonate, aqueous solution	10%	+
Butyl acetate	-	0	Hydrogen sulphate saturated	-	+	Sodium chloride, aqueous solution	10%	+
Calcium chloride, solution	10%	+	Ink	-	+	Sodium nitrate, aqueous solution	10%	+
Carbon trachloride	-	-	Iodine solution, alcohol solution	-	+	Sodium thiosulphate, aqueous solution	10%	+
Chlorbenzene	-	+	Iso-octane	-	+	Styrene	-	0

KEY

+	Resistant	0	Limited Resistance	-	Not Resistant
---	-----------	---	--------------------	---	---------------

NB: Factors such as temperature, time, concentration, duration and mechanical load will all affect the resistance of a material to a chemical.

AGENT	CONCENTRATION (WEIGHT %)	POLYPROPYLENE (HOMOPOLYMER)	AGENT	CONCENTRATION (WEIGHT %)	POLYPROPYLENE (HOMOPOLYMER)	AGENT	CONCENTRATION (WEIGHT %)	POLYPROPYLENE (HOMOPOLYMER)
Chloroform	-	0	Isopropanol	-	+	Sulphur dioxide	-	+
Citric acid, aqueous solution	10%	+	Lactic acid, aqueous solution	10%	+	Sulphuric acid, aqueous solution	2%	+
Cupric sulphate	10%	+	Lactic acid, aqueous solution	90%	+	Sulphuric acid, concentrated	98%	+
Cyclohexane	-	+	Linseed oil	-	+	Tar	-	+
Cyclohexanone	-	+	Methanol	-	+	Tartaric acid	-	+
Decalin	-	+	Methyl ethyl ketone	-	+	Tetrahydrofurane	-	0
Diesel Oil	-	0	Methylene chloride	-	-	Tetralin	-	-
Dimethyl formamide	-	+	Milk	-	+	Toluene	-	+
Diethyl phthalate	-	+	Nitric acid, aqueous solution	2%	+	Transformer oil	-	0
Dioxane	-	+	Nitrobenzene	-	+	Trichlorethylene	-	0
Edible fats, Edible oils	-	+	Oxalic acid, aqueous solution	10%	+	Triethanolamine	-	+
Ethanol	96%	+	Paraffin oil	-	+	Urea, aqueous solution	-	+
Ethyl acetate	-	+	Perchlorethylene	-	-	Vaseline	-	+
Ethyl ether	-	+	Petroleum	-	+	Water, cold	-	+
Ethylene chloride	-	+	Phenol, aqueous solution	-	+	Water, warm	-	+
Formaldehyde, aqueous solution	30%	+	Phosphoric acid, concentrated	-	+	Wax, molten	-	0
Formic acid, aqueous solution	10%	+	Potassium dichromate, aqueous solution	10%	+	Wine, Brandy	-	+
Freon, Frigen, liquid	-	-	Potassium lye, aqueous	10%	+	Xylene	-	-
Fruit Juices	-	+	Potassium lye, aqueous	50%	+	Zinc chloride, aqueous solution	10%	+

KEY

+	Resistant	0	Limited Resistance	-	Not Resistant
---	-----------	---	--------------------	---	---------------

NB: Factors such as temperature, time, concentration, duration and mechanical load will all affect the resistance of a material to a chemical.



Plumbing & Drainage

Ireland

24 Roughfort Road
Mallusk, Co. Antrim
Northern Ireland, BT36 4RB
Tel: 028 9084 9999
Fax: 028 9083 6666
Sales Counter: 028 9084 8999
Email: sales@brettmartin.com

England & Wales

Speedwell Ind. Estate
Staveley, Derbyshire
England S43 3JP
Tel: 01246 280000
Fax: 01246 280001
Email: building@brettmartin.com

100 Camford Way
Sundon Park
Luton, Bedfordshire
England, LU3 3AN
Tel: 01246 280000
Fax: 01246 280001
Email: building@brettmartin.com

Scotland

Blairlinn Road
Cumbernauld, Glasgow
Scotland, G67 2TF
Tel: 01236 725536
Fax: 01236 725871
Email: scotland@brettmartin.com

For the latest company information
visit the company's website:
www.brettmartin.com



All reasonable care has been taken in the compilation of the information contained within this literature. All recommendations on the use of our products are made without guarantee as conditions of use are beyond the control of Brett Martin. It is the customer's responsibility to ensure that the product is fit for its intended purpose and that the actual conditions of use are suitable. Brett Martin pursues a policy of continuous product development and reserves the right to amend specifications without prior notice. StormCrate55 is a registered trademark of Brett Martin Ltd. Brett Martin Ltd's Normal Conditions of Sale apply.